



Installation and Maintenance Manual

CTC EcoPack 2.0

Modell 38 / 54 / 80 / 100



Translation of the original instructions.
Keep for future use.
Read carefully before use.

Table of contents

1.	Important to remember!	3	9.	Operating limit for heat exchanger	10
2.	Overview	4	10.	Measurements	11
3.	Components and design	4	11.	Electrical installation	12
3.1	DHW heat exchanger	4	12.	Installation.....	13
3.2	Electrical equipment.....	4	13.	Troubleshooting.....	14
3.3	DHW heat exchanger	4	13.1	Potential problems and how to remedy them.....	14
4.	Safety instructions	5	14.	Maintenance.....	14
5.	Installation.....	6	15.	Hydraulic schematics.....	15
6.	Function description of the control unit.....	7	16.	Key for hydraulic schematics.....	18
7.	Installation.....	8			
7.1	Installation space	8			
7.2	Temperature (primary side/primary flow).....	8			
8.	Technical data.....	9			
8.1	CTC EcoPack 2.0 DHW heat exchanger	9			

1. Important to remember!

Ensure that you check the following points upon delivery and installation:

- Remove the packaging and check that the product (electrical connection box and display) has not been damaged in transit. Report any transport damage directly to the carrier.
- Check for missing parts.
- The DHW heat exchanger is intended to be installed in a dry space indoors.
- The product must not be installed where the ambient temperature is lower than 10°C.
- The product must not be installed where the ambient temperature is higher than 50°C.

Recycling

- The product packaging material must be disposed of in an environmentally correct manner.
- The product must not be disposed of together with standard waste at the end of its service life. Used products must be disposed of in an environmentally correct manner by an approved body.



Information in this type of box [!] is particularly important for correctly installing and using the product.



Information in this type of box [i] is intended to help ensure that the product functions optimally.

2. Overview

The water heater is used to hygienically heat drinking water. The hot water from the heat pump heats the drinking water which is drawn off via a heat exchanger. The built-in electronic control defines the draw-off temperature during the draw-off process. To use the water heater in your home, you need:

- A heat pump or other heat generator.
- An accumulator for hot water (storage tank for charging).

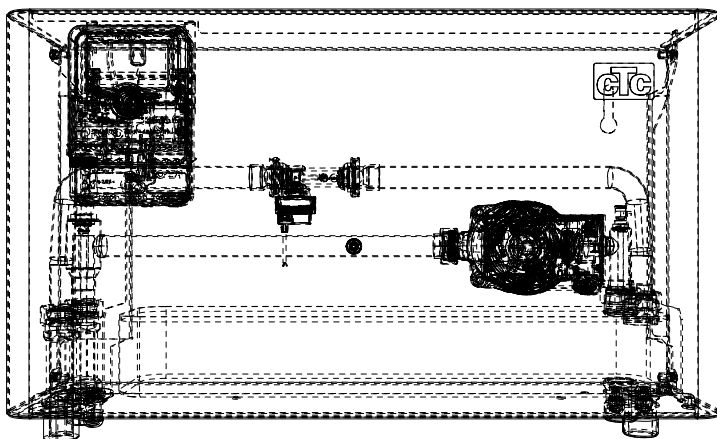

3. Components and design

3.1 DHW heat exchanger

All components in the DHW heat exchanger are installed in a protective body made of steel plate, which is intended to be hung on the wall. The basic frame consists of bent, thick-walled steel plate. It is firmly attached to the frame and lid of the rear side. The front plate forms a unit with the side plate and is detachable.

All parts of the body are reliably and permanently protected by a fireproof powder coating.

3.2 Electrical equipment

- Control unit and display with control panel
- 230-V power cable

3.3 DHW heat exchanger

- Stainless steel plate heat exchanger manufactured using a high-vacuum soldering technique that results in low pressure losses.
- Circulation pump, primary flow: Wilo Yonos PARA 15/1-7.5 130 PWM
- Sensor for primary flow temperature
- Flow and temperature sensor

1.1.1 List of accessories and connection devices

Quantity	Designation
2	Plastic plug, W x L = 10 mm x 50 mm
2	Hex head wood screw, length 50 mm, D=8 mm, screw for wall mounting

4. Safety instructions



The installation should be preceded by an omnipolar safety switch according to overvoltage category III, which ensures disconnection from all electric power sources.

Turn off the power with an omnipolar switch before doing any work on the product.



The product must be connected to protective earth.



The product is classified as IP X1. The product must not be rinsed with water.



Never jeopardise safety by removing bolted covers, hoods or similar.



Service of the product's electrical system must only be carried out by a qualified electrician in compliance with the specific requirements of the national standard for electrical safety.

Replacement of damaged supply cable, must be carried out by the manufacturer or qualified service engineer to avoid risk.



The product must not be started if it is not filled with water; instructions are in the "Pipe installation" section.



This device can be used by children from the age of eight years and above and by people with reduced physical, sensory or mental ability or lack of experience or knowledge if they have been taught, either with supervision or with the instructions provided, how to use the device safely and understand the risks involved. Children should not play with the device. Cleaning and maintenance should not be carried out by children without supervision.



If these instructions are not followed when installing, operating and maintaining the system, CTC's commitment under the applicable warranty terms is not binding.

5. Installation

The DHW heat exchanger is used to hygienically heat drinking water. The hot water from the heat pump heats the drinking water which is drawn off via a heat exchanger. The built-in electronic control defines the draw-off temperature during the draw-off process. To use the water heater in your home, you need:

- A heat pump or other heat generator.
- An accumulator tank for drinking water (storage tank for charging).

Your CTC EcoPack DHW heat exchanger has been designed and built taking into consideration risk analyses and entirely in accordance with relevant standards.

This means that your DHW heat exchanger meets the latest technical standards and ensures the highest conceivable levels of safety. In practice, these safety levels can only be achieved if all necessary measures are adopted. As the user of the DHW heat exchanger, you are responsible for arranging these measures and checking they are implemented.

You must ensure that:

- The DHW heat exchanger is only used for the intended purpose.
- The DHW heat exchanger is only used when it is entirely free from errors and in working order.
- The installation and maintenance instructions are always free from errors and available in the vicinity of the DHW heat exchanger.
- Only sufficiently qualified and authorised personnel use, maintain and repair the DHW heat exchanger.
- No safety or warning instructions on the DHW heat exchanger are removed or damaged.



Risk of burns!

During operation, surface temperatures (on the heat exchanger) can reach over 60°C. Do not remove the casing of the unit during operation! Allow the heat exchanger to cool before removing the casing.



Risk of damage to the equipment due to calcification!

To avoid calcification in the unit, we recommend that the system works at water temperatures below 60°C. Damage that is caused by deposits or calcification is not covered by the guarantee.

6. Function description of the control unit

The control unit controls the circulation pump on the primary side in order to achieve the lowest possible return flow temperature in the heating circuit based on the quantity of hot tap water and the primary flow temperature in the heating system. The hot water temperature always corresponds to the setpoint that is set on the control unit. If the accumulator tank becomes too cold, i.e. if the temperature level in the heating circuit is so low that the set DHW temperature can no longer be reached, adjust the setpoint. This means that the setpoint of the DHW should be reduced until the set hot water temperature is reached again. This is called a "sliding setpoint". Schematic illustration with the sensors that are required for control are presented in Figure 1.

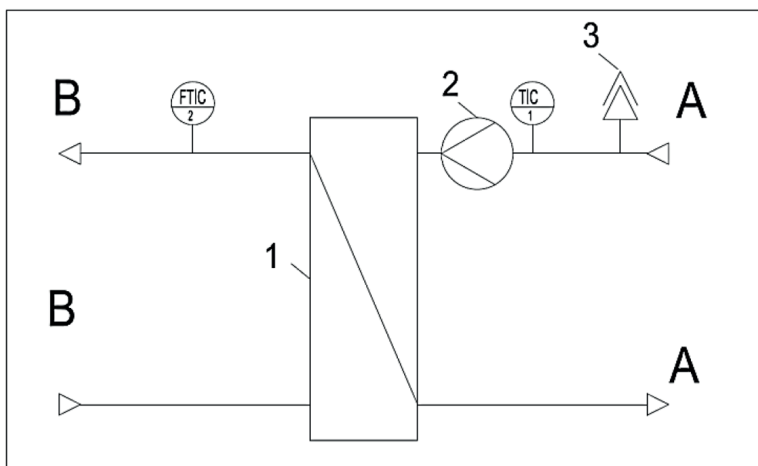

Figure 1. DHW heat exchanger

1	Plate heat exchanger
2	Circulation pump
3	Quick bleeder
TIC 1	Temperature sensor
F TIC 2	Flow/temperature sensor
A	Primary side (heating water)
B	Secondary side (hot tap water)

7. Installation

The compact DHW heat exchanger is installed suspended on the wall. Screws and rawl plugs for wall mounting are provided. The connections of the DHW heat exchanger are placed on the underside. The position of the drill holes is shown in Figure 3.

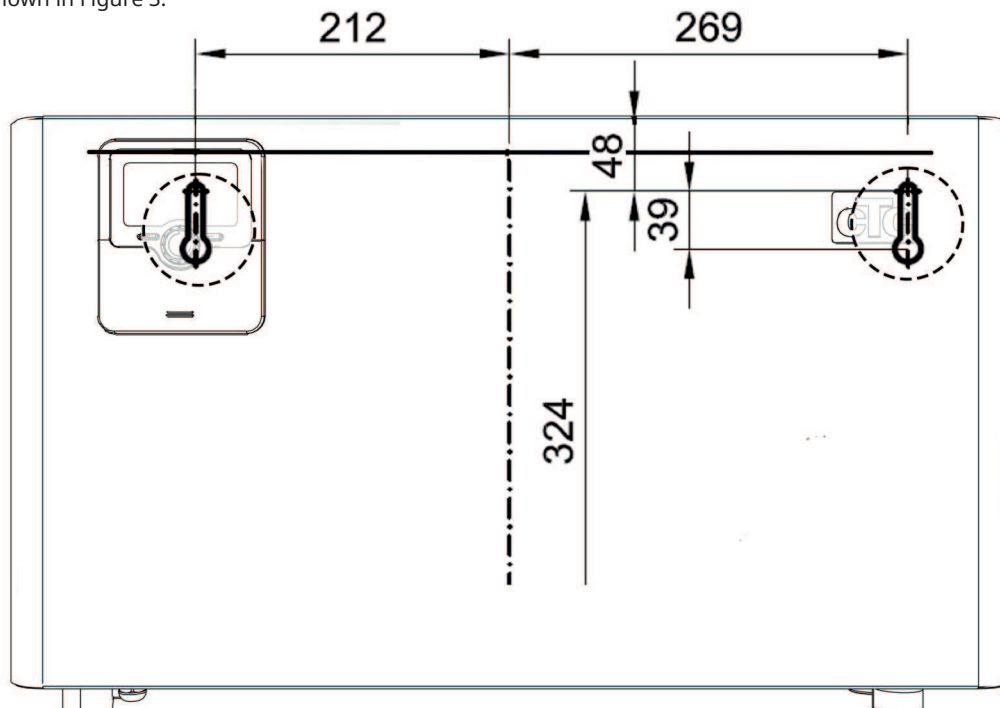

Figure 3. Drill pattern for DHW heat exchanger

Method:

- Remove the four socket head screws on the side of the unit and the front plate.
- Drill two holes with the correct spacing (see the drill pattern). Check that the unit is installed horizontally.
- Insert the accompanying rawl plugs into the drill holes and screw in the accompanying screws so that they project around 5 mm.
- Suspend the unit and anchor it to the wall with the screws.
- Once the connections of the DHW heat exchanger have been attached, install the front plate and secure it with the socket head screws.

7.1 Installation space

The DHW heat exchanger is intended to be installed in a dry space indoors. The ambient temperature should be between +10°C and +30°C.

7.2 Temperature (primary side/primary flow)

The temperature on the primary side should be limited to 60°C. This minimises the risk of calcification considerably while simultaneously acting as protection against deposits. In addition, heat losses via pipelines are significantly reduced, which results in higher heat utilisation in the solar heating system. To limit the temperature, we recommend installing a thermostatic mixing valve at the tank outlet.

8. Technical data

8.1 CTC EcoPack 2.0 DHW heat exchanger

	Unit	EcoPack 38	EcoPack 54	EcoPack 80	EcoPack 100
Article number		590004011	590004012	590004013	590004014
RSK no.		6936011	6936012	6936013	6936014
Product data number (GTIN/EAN)		7333077102968	7333077102975	7333077102982	7333077102999
General data					
Weight of unit, empty	kg	21	23	25	27
Connections		flat face 1"			
Dimensions W x H x D	mm	670 x 375 x 182			
Capacity					
Tap capacity (55°C tank temperature/heating of drinking water from 10°C to 50°C)	l/min	13.7	19.3	28.7	38.8
Tap capacity (55°C tank temperature/heating of drinking water from 10°C to 40°C)	l/min	21.7	28.2	40.3	49.5*
Max. Energy consumption, Circulation pump	W	76	76	76	76
Control unit power consumption	W	1	1	1	1
Residual pressure head (55°C tank temperature/heating of drinking water from 10°C to 40°C)	kPa	49	48	31	20
	m ³ /h	1.0	1.3	1.9	2.3
Approximate maximum pipe length at above-mentioned residual pressure head (calculated as below)		90-metre 22x1 Cu pipe	59-metre 22x1 Cu pipe	20-metre 22x1 Cu pipe**	20-metre 22x1 Cu pipe**
Operating limit	°C	90	90	90	90
Max. operating pressure, primary (tank-heat pump)/secondary (DHW):	bar	2.5/10	2.5/10	2.5/10	2.5/10
Pressure loss on drinking water side					
Input temperature	°C	10	10	10	10
Output temperature	°C	50	50	50	50
Flow rate	m ³ /h	0.9	1.2	1.8	2.1
Pressure loss	mWS	2.0	2.2	2.2	1.4
Electrical data 1x230 V, 50 Hz					
Max. operating current	A	2	2	2	2
Main fuse on building side	A	10	10	10	10
*The value no longer appears on the control unit display, but is the maximum that can be tapped off.					
**For these variants, we recommend 28x1.5 Cu pipes.					

9. Operating limit for heat exchanger

The soldered plate heat exchanger consists of imprinted, stainless steel plates, type 1.4401 and AISI 316, respectively. This means that the corrosion behaviour of the stainless steel as well as lubricants, copper or nickel must be considered.

Waterproof part + parameter	Unit	Plate heat exchanger, copper-brazed (standard)	Plate heat exchanger nickel-brazed (standard)
pH value		7-9 (considering SI index)	6-10
Saturation index S (ΔpH value)		-0.2 < 0 < +0.2	not defined
Total hardness	°dH	6-15	6-15
Conductivity	μS/cm	10-500	not defined
Filterable substances	mg/l	< 30	< 30
Chlorides (Cl ⁻)	mg/l	see the diagram below, no chlorides are permitted above 100°C	
Free chlorine	mg/l	< 0.5	< 0.5
Hydrogen sulphide (H ₂ S)	mg/l	< 0.05	not defined
Ammonia (NH ₃ /NH ₄ ⁺)	mg/l	< 2	not defined
Sulphate (SO ₄ ²⁻)	mg/l	< 100	not defined
Hydrogen carbonate (HCO ₃ ⁻)	mg/l	< 300	not defined
Hydrogen carbonate/sulphate	mg/l	> 1	not defined
Sulphite (SO ₃ ²⁻)	mg/l	< 1	not defined
Nitrate (NO ₃ ⁻)	mg/l	< 100	not defined
Nitrite (NO ₂ ⁻)	mg/l	< 0.1	not defined
Iron, dissolved (Fe)	mg/l	< 0.2	not defined
Manganese (Mn)	mg/l	< 0.1	not defined
Free aggressive carbonic acid (H ₂ CO ₃)	mg/l		not defined

The above values are provided as guidelines that may vary under certain conditions.

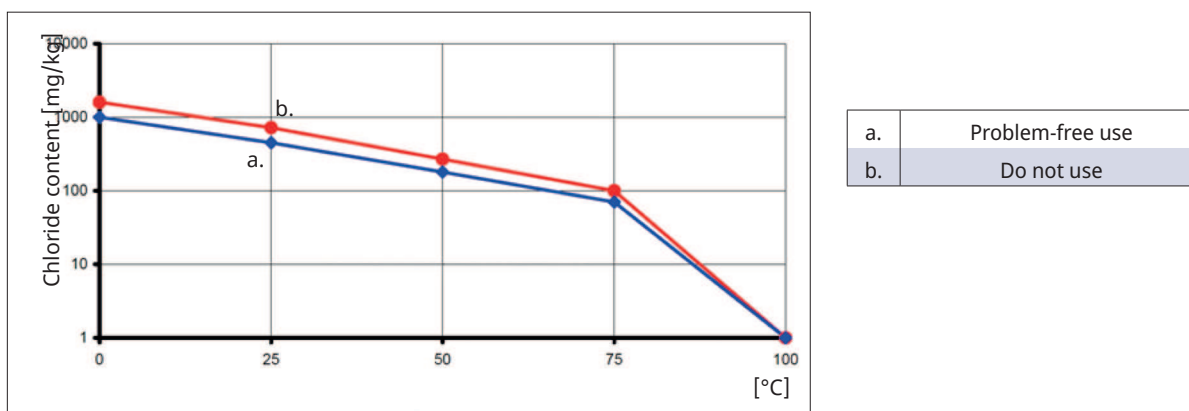
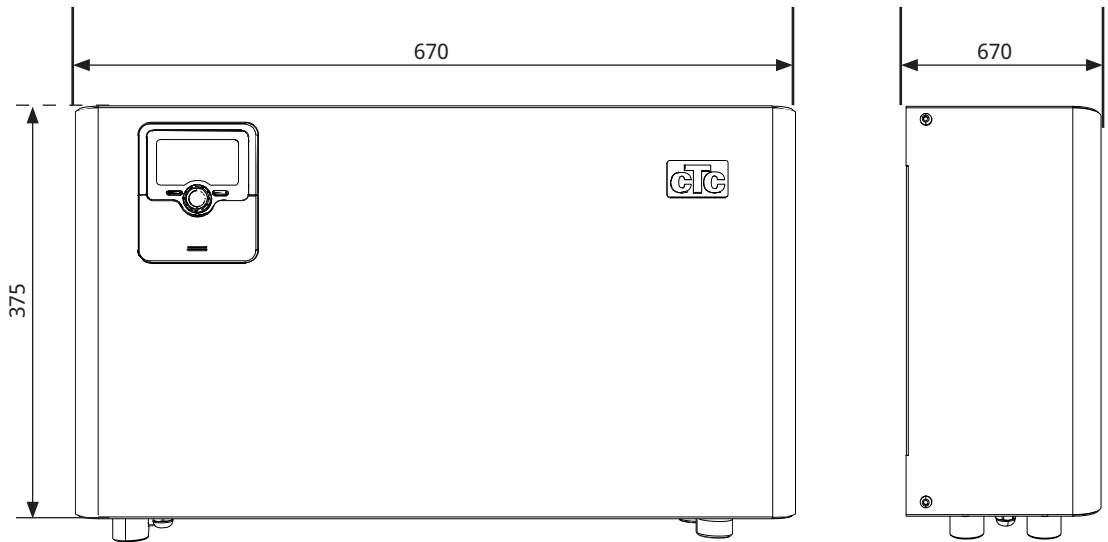
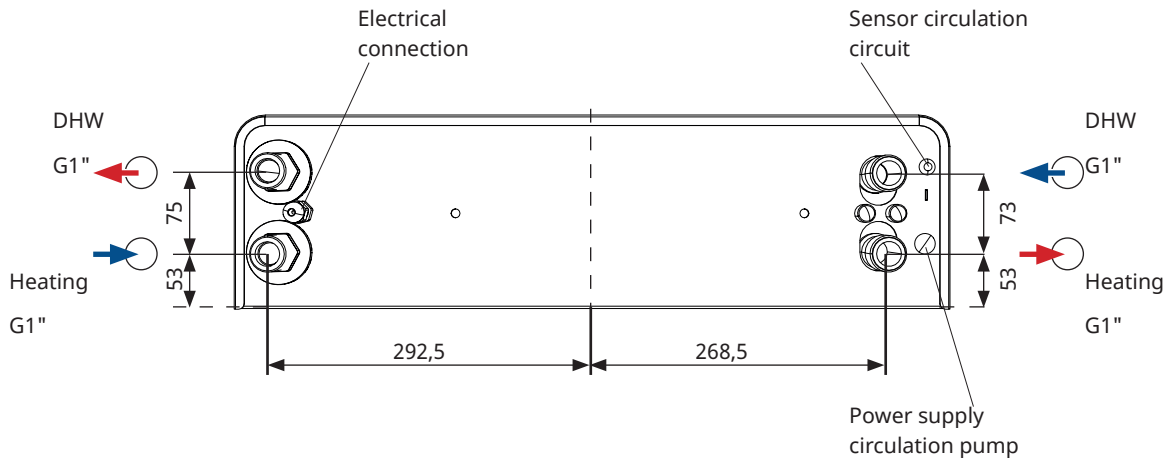

Figure 5: Permitted chloride content depending on the temperature

10. Measurements



11. Electrical installation



NOTE!
Risk of irreparable damage!
The unit must only be connected to the mains network once the circuits of the DHW heat exchanger have been filled and bled.

The power supply line is equipped with a Schuko plug that is connected to the mains network. It is used to separate the unit from the mains network if needed (installation/repair).

CTC EcoPack 2.0

The illustration is only intended for illustrative purposes and is not legally binding. All specifications and cable dimensions must be established by a qualified electrician in accordance with generally applicable standards. Shielded cables must have the shielding connected to GND or PE.

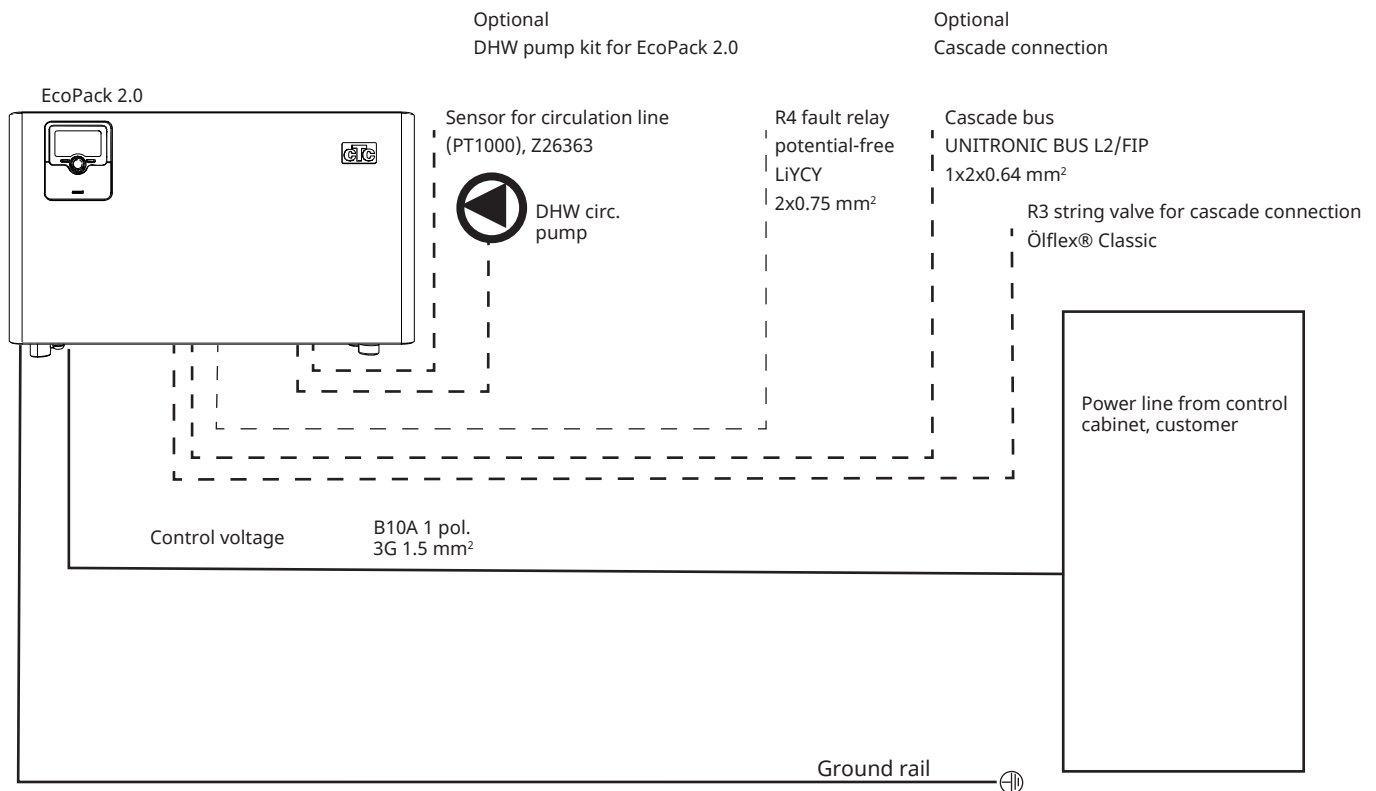

12. Installation

Method:

- All the connections of the DHW heat exchanger are installed.
- Fill the circuits with water and bleed them.
- Check that the bolted joints are tight and tighten if necessary.
- Check that the minimum flow is ensured using the circulation pump. The flow must be at least 2.5 l/min for the primary pump to supply sufficient heat.
- Connect the power supply cable of the circulation pump.
- Connect the power plug to the mains network.
- Tap water. The DHW heat exchanger automatically starts when the hot water is withdrawn.

Reference: The DHW heat exchanger is equipped with a powerful electronic control unit. All necessary settings and options are described in the user instructions of the control unit. Depending on the on-site design of the system, short-term temperature fluctuations may occur when hot water is withdrawn

13. Troubleshooting

13.1 Potential problems and how to remedy them

The DHW heat exchanger does not work:

- Check the power supply.
- Check the heat circulation pump.
- Check the flow sensor.
- Check the temperature sensor.
- Check the tank temperature.

14. Maintenance

Ensure that the DHW heat exchanger receives annual maintenance. This will allow you to ensure that the system runs reliably and efficiently. Your service partner can provide further information.

15. Hydraulic schematics

Hydraulic schematic 1

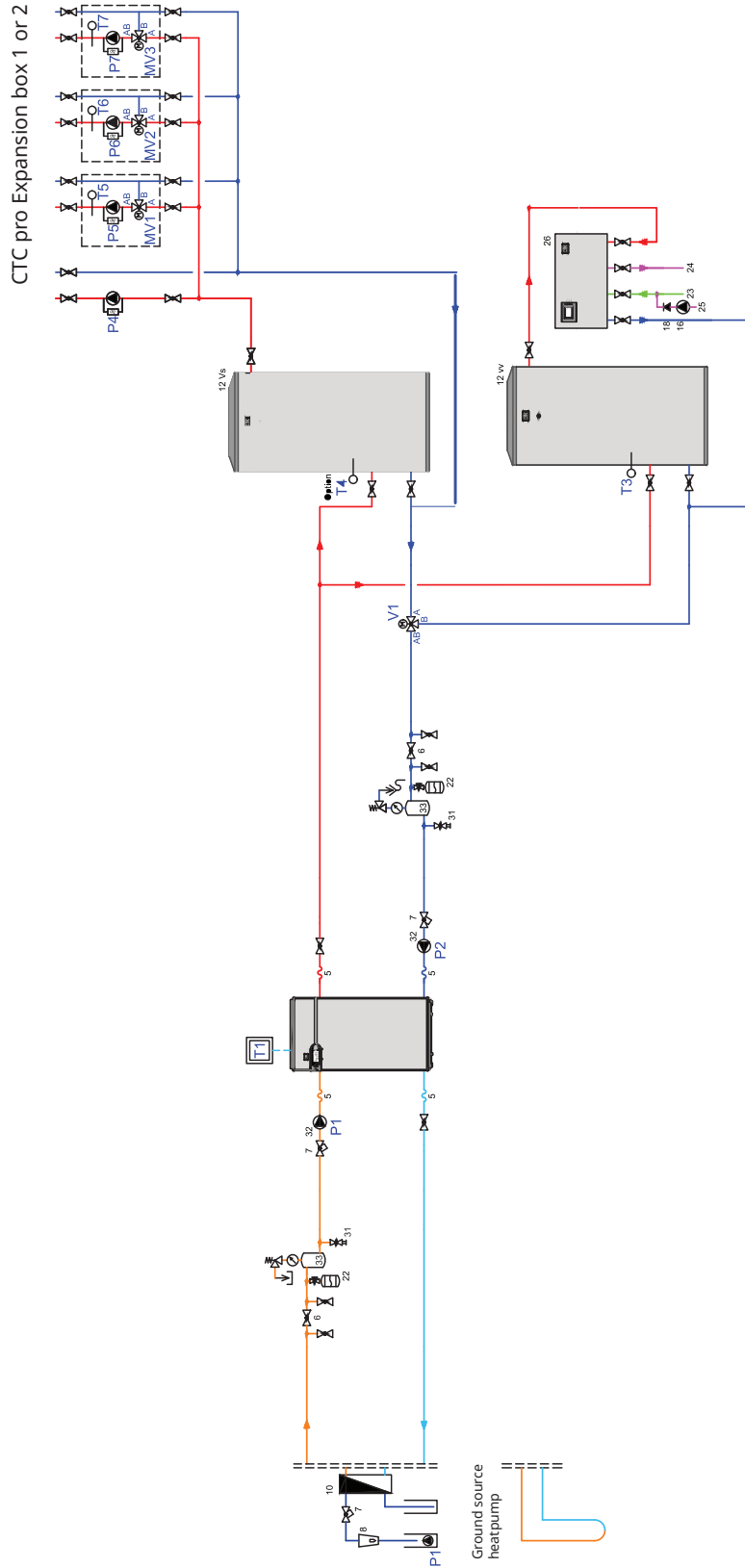

OBSt Detta är ett principschema. Verklig anläggning skall projekteras enligt gällande normer.

Note! This is a schematic diagram; the actual system must be design in accordance with the current standards.

Hinweist Dies ist ein Prinzipschema. Die tatsächliche Anlage muss gemäß den aktuellen Standards ausgelegt sein.

Hydraulic schematic 2

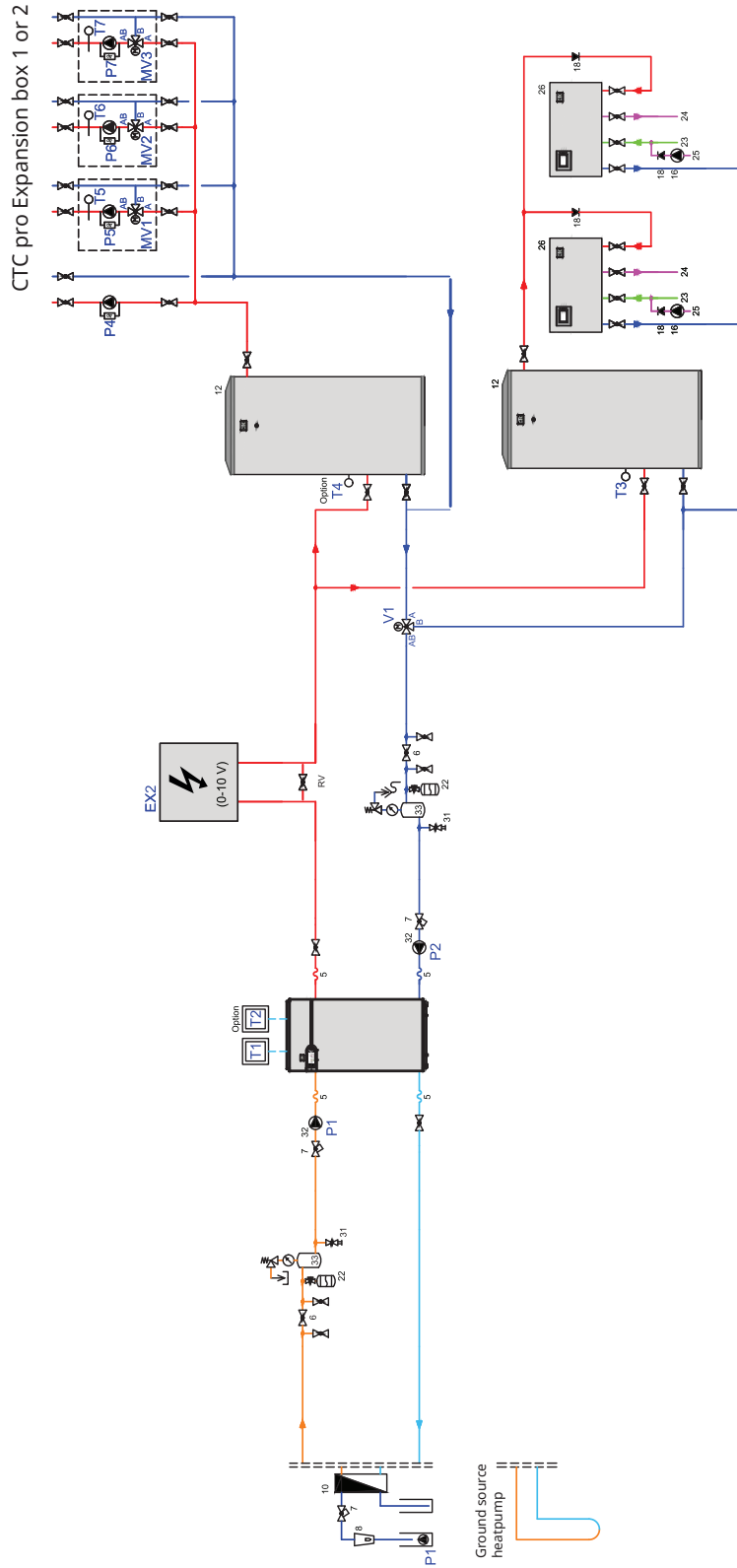

Hinweis! Dies ist ein Prinzipschema. Die tatsächliche Anlage muss gemäß den aktuellen Standards ausgelegt sein.

Note! This is a schematic diagram; the actual system must be design in accordance with the current standards.

OBS! Detta är ett prinsipschema. Verklig anläggning skall projekteras enligt gällande normer.

Hydraulic schematic 3

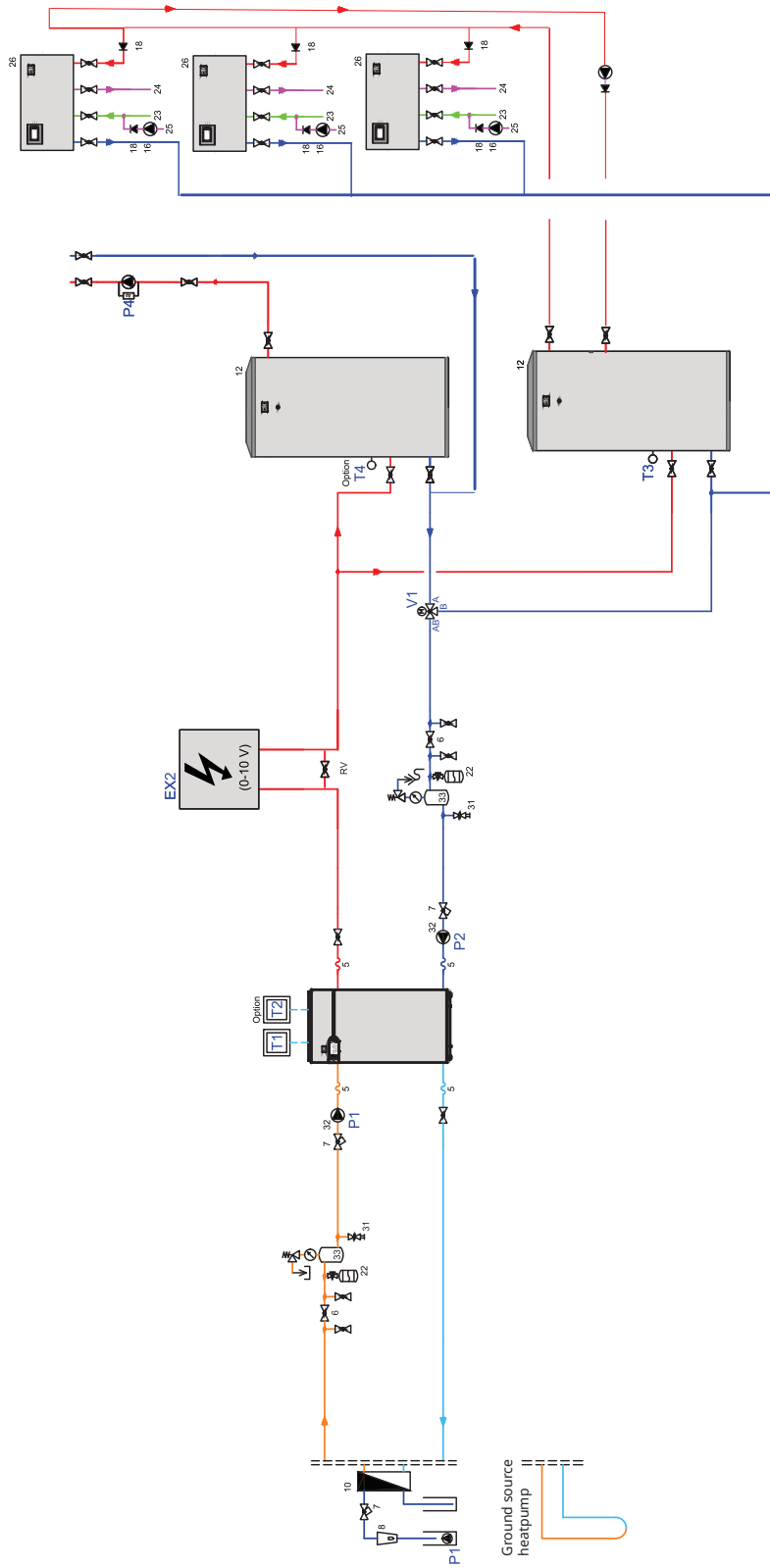

Hinweis! Dies ist ein Prinzipschema. Die tatsächliche Anlage muss gemäß den aktuellen Standards ausgelegt sein.

Note! This is a schematic diagram; the actual system must be design in accordance with the current standards.

OBST! Detta är ett prinsipschema. Verklig anläggning skall projekteras enligt gällande normer.

16. Key for hydraulic schematics

No.	Description
1	Underfloor
2	Heat pump
3	Indoor module
4	Outdoor module
5	Flexible connections
6	Connection group for flushing and ventilation
7	Filter integrated in the ball valve
8	Monitoring of flow rate
9	Groundwater pump
10	Plate heat exchanger
11	Motorised switching speed (interruption-free)
12	Optimised heat storage (charge storage)
13	Optimised heat storage (storage of returning series)
14	Temperature sensor
15	Radiators or convectors
16	Bronze pump
17	Pressure reducer
18	Non-return valve
19	Safety valve
20	Valve, rule difference 1 to 2 Kelvin
21	Membrane expansion tank for drinking water system
22	Membrane expansion tank
23	Cold water
24	DHW
25	DHW circ.
26	EcoPack DHW heat exchanger
27	Water heater
28	Air separator with air source
29	Pressure relief valve with differential pressure
30	Pressure-controlled circulation pump
31	Filling and emptying valve
32	Circulation pump
33	Air separator with air valve, pressure gauge and safety valve
34	Safety group
35	Safety valve with air valve and pressure gauge
36	TacoSetter for hydraulic balancing
37	Tank for charging
38	Pool
39	Mixing valve
40	Membrane expansion tank solar with shut-off valve
41	Module for heat source
42	Heat source module natural cooling
43	Motorised switching valve, continuous (heating and cooling)
44	2nd heat generator

No.	Description
45	Non-return valve
46	Line regulating valve for hydraulic balancing
47	Splash guard sleeves
48	Motorised switching valve
49	Motorised valve
50	Connections to integrated tubular heat exchanger
51	Heat exchanger for pool
52	Ball valve
53	Optimised heat storage tank with integrated heat exchanger with flat coil
54	Collector
55	Storage tank
56	Thermostatic valve
57	Temperature regulator
58	Gravitational brake
59	Tichelmann hydraulic extension set
60	Tichelmann hydraulic basic set-up
61	Set for connecting solar cells
62	Sensor for collector temperature
63	Vacuum pipe
64	Electric heating with resistance
65	Charging reservoir 400 l with water heater for household use (SET 454)
66	Check valve
67	Sensor for outdoor temperature
68	Pilot room sensor
69	Motorised ball valve
70	Safety group with safety valve, pressure reducer, backflow protection and membrane expansion tank with flow valve for drinking water system
71	215-litre plastic container
72	Funnel
73	Copper tube, copper with suction filter, non-return valve and pump connection
74	Self-priming pump WJ 301 EM with 2-m connection cable (230 V), input power 1100 W, connections on suction and pressure side Rp1"
75	1500-mm flow hose with 1 1/4" connection nut with 2 gaskets and reducer 1 1/4" a x 1" a
76	1500-mm return hose with 1 1/4" connection nut with 2 gaskets
77	Air separator, safety group with pressure gauge, air trap, safety valve, membrane expansion tank with shut-off valve
78	Motorised switching ball valve (heating hot water for domestic use)
79	Motorised ball valve with switching (swimming bath/pool)
80	Multi-layer filter for cleaning pool water
81	Pool water — disinfection device
82	PH — device for checking and correcting values
83	Water drainage in the pool
84	Circulation pump for pool water



CTC AB
Box 309 SE-341 26 Ljungby
+46 372 88 000
info@ctc.se
www.ctc.se