



Installation and Maintenance manual

## **CTC EcoPart 600M**

Modulating ground source heat pump

Model 612M / 616M

400V 3N~



**Translation of the original instructions.**

**Keep for future use.**

**Read carefully before use.**

162 505 83-4 CR01132 2025-11-03



MADE IN SWEDEN

# Removing the cooling module



- Any work done on the product's cooling system should be done by authorised personnel only.
- Close the safety switch before doing any work on the product.

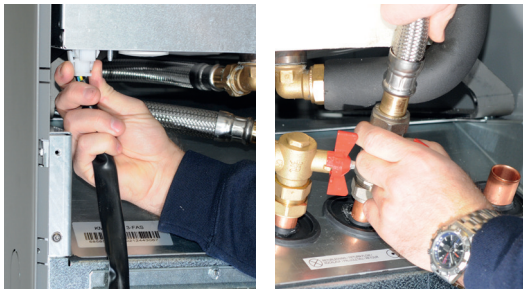

1. Disconnect the cooling module's power cable connector and hoses.



2. Attach the two carrying handles to the bottom of the cooling module.



3. Unscrew the cooling module's screws.
4. Fold out the front cable harness and loosen the flat pin on the red EMC cable.



5. Pull the cooling module by first lifting the front edge slightly with the carrying handles.



6. Lift the cooling module using the carrying handles and shoulder straps.

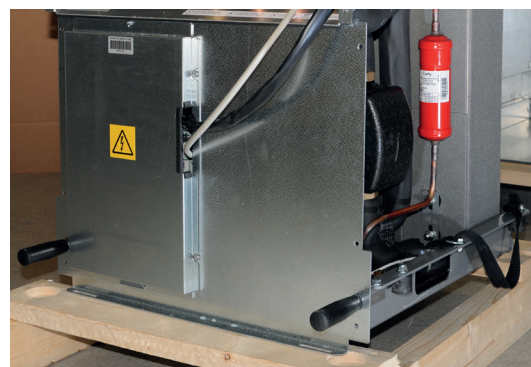

7. Lift the cooling module into the product using the carrying handles and shoulder straps. Remove the carrying handles and reconnect the power cable, hoses and screws.
8. Before the cooling module is tightened into position, ensure the EMC cable is affixed.

Installation and Maintenance manual

## **CTC EcoPart 600M**

Modulating ground source heat pump

400V 3N~

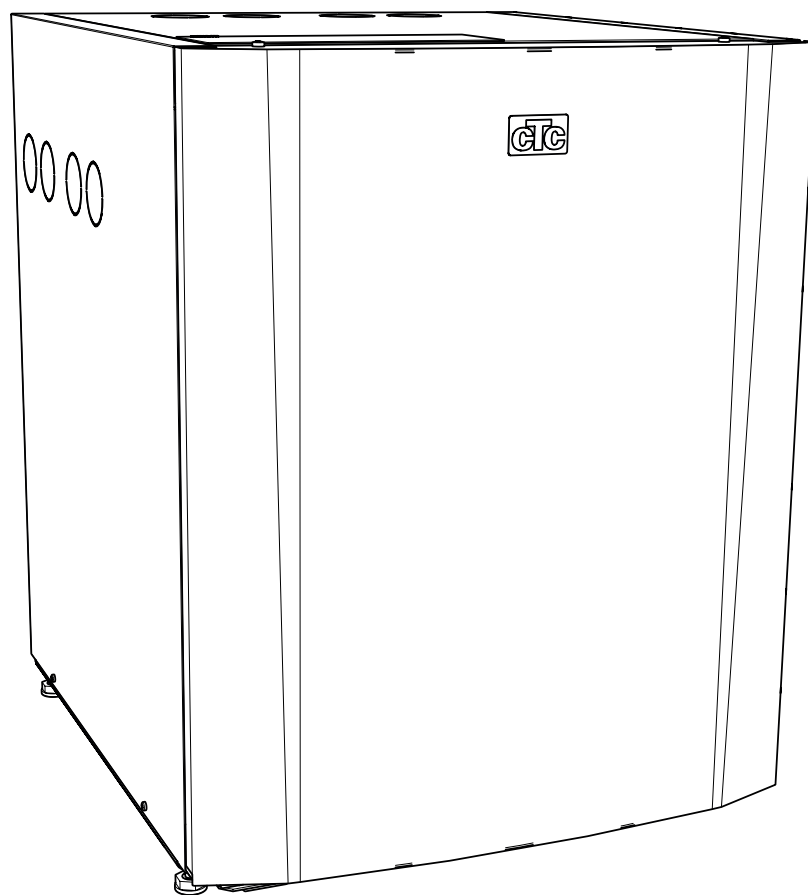

## Table of Contents

<b>1. Important to remember!</b> .....	<b>6</b>	<b>8. Electrical installation</b> .....	<b>21</b>
1.1 Transportation.....	6	8.1 Electric installation 400V 3N~.....	21
1.2 Positioning.....	6	8.2 Communication connection.....	22
1.3 Recycling.....	6	8.3 Option 1 - Connection of one heat pump.....	22
1.4 After commissioning.....	6	8.4 Option 2 - Series connection of heat pumps.....	23
<b>2. Safety instructions</b> .....	<b>7</b>	8.5 Connecting the control system.....	24
<b>3. Checklist</b> .....	<b>8</b>	8.6 Wiring diagram.....	29
<b>4. Connection options</b> .....	<b>9</b>	8.7 Parts list.....	31
<b>5. Technical data</b> .....	<b>10</b>	8.8 Resistances for sensors.....	32
5.1 CTC EcoPart 612M.....	10	<b>9. First start</b> .....	<b>33</b>
5.2 CTC EcoPart 616M.....	11	<b>10. Operation and Maintenance</b> .....	<b>33</b>
5.3 Component location cooling module.....	12	10.1 Periodic maintenance.....	33
5.4 Dimensions diagram.....	13	10.2 Operation stop.....	33
5.5 Refrigerant system.....	14	<b>11. Troubleshooting</b> .....	<b>34</b>
5.6 Delivery includes.....	14	11.1 Air problems.....	34
<b>6. Installation</b> .....	<b>15</b>	11.2 Alarm.....	34
6.1 Connection of the heat medium side.....	15		
<b>7. Connecting the cold carrier system (brine system)</b> .....	<b>17</b>		
7.1 Connections.....	17		
7.2 Brine system schematic diagram.....	18		
7.3 Coolant pump (G20).....	20		

## Software update



software.ctc.se

EN

For more information on updated functions and downloading the latest software, see the website "software.ctc.se".

## Congratulations on buying your new product!



### The complete heat pump for rock, ground or lake

The CTC EcoPart 600M is a modulating heat pump which takes heat from bedrock, ground or watercourses, and delivers it to the house's existing heating system.

The heat pump can be connected to the CTC EcoZenith i550 Pro\*, CTC EcoZenith i555 Pro, CTC EcoZenith i360, CTC EcoVent i360F or to the existing heating circuit via the CTC EcoLogic control system.

CTC EcoPart 600M has been designed to operate with high efficiency and low noise levels.

Save this manual containing the installation and maintenance instructions. If it is looked after properly, you will be able to enjoy the use of your CTC EcoPart 600M for many years. This manual will provide all the information you will need.

CTC EcoPart 600M is available in two versions:  
CTC EcoPart 612M and CTC EcoPart 616M.

# 1. Important to remember!

Check the following points in particular at the time of delivery and installation:

## 1.1 Transportation

- Transport the heat pump to the installation location before removing the packaging. Move the product using one of the following means:
  - Forklift
  - Lifting band around the pallet.
 NB: Can only be used with the packaging on.
- The heat pump must be transported and stored upright.

## 1.2 Positioning

- The heat pump must be transported and stored upright.
- Remove the packaging and check before installation that the product has not been damaged in transit. Report any transport damage to the carrier.
- Place the product on a solid foundation, preferably concrete. If the heat pump needs to be placed on a soft carpet, base plates must be placed under the adjustable feet.
- Remember to leave an access and service area of at least 1 metre in front of the heat pump.
- The heat pump must not be placed below floor level.
- Avoid placing the heat pump in rooms where the walls are of lightweight design, as people in the adjoining room may be disturbed by the compressor and vibrations.

**When contacting CTC, always mention the following:**

- Serial number
- Model/Size
- the fault message shown in the display
- Phone number

## 1.3 Recycling

- The packaging must be deposited at a recycling station or with the installation engineer for correct waste management.
- Obsolete products must be disposed of correctly and transported to a waste station or distributor/retailer offering this service. Disposal of the product as household waste is not permitted.
- It is very important that the product's refrigerant, compressor oil and electric/electronic components are disposed of correctly.

## 1.4 After commissioning

- The installation engineer advises the property owner on the design and servicing of the system.
- The installation engineer fills in a checklist and contact information – the customer and installation engineer sign the list, which the customer keeps.
- Make sure that registration for warranty and insurance is made on the CTC's web site: <https://www.ctc-heating.com/customer-service#warranty-registration>

 Information in this type of box [i] is intended to help ensure that the product functions optimally.

 Information in this type of box [!] is particularly important for correctly installing and using the product.

Fill in the information below. It may come in useful if anything should happen.

Product:	Serial number:
Installer:	Name:
Date:	Tel. no.:
Electrical installer:	Name:
Date:	Tel. no.:

No liability is accepted for any misprints. We reserve the right to make design changes.

## 2. Safety instructions



The installation should be preceded by an omnipolar safety switch according to overvoltage category III, which ensures disconnection from all electric power sources.

Turn off the power with an omnipolar switch before doing any work on the product.



The product must be connected to protective earth.



The product is classified as IPX1. The product must not be rinsed with water.



When handling the product with a hoist ring or similar device, make sure that the lifting equipment, eyebolts and other parts are not damaged. Never stand under the hoisted product.



Never jeopardise safety by removing bolted covers, hoods or similar.



Any work on the product's cooling system should be carried out by authorised personnel only.



Installation and connection in the product must be carried out by a authorised electrician. All piping must be installed according to the applicable requirements.

Service of the product's electrical system must only be carried out by a qualified electrician in compliance with the specific requirements of the national standard for electrical safety.

Replacement of damaged supply cable, must be carried out by the manufacturer or qualified service engineer to avoid risk.



Safety valve check:

-Safety valve for boiler/system to be checked regularly.



The product must not be started if it is not filled with water; instructions are in the "Pipe installation" section.



This device can be used by children from the age of eight years and above and by people with reduced physical, sensory or mental ability or lack of experience or knowledge if they have been taught, either with supervision or with the instructions provided, how to use the device safely and understand the risks involved. Children should not play with the device. Cleaning and maintenance should not be carried out by children without supervision.



If these instructions are not followed when installing, operating and maintaining the system, Enertech's commitment under the applicable warranty terms is not binding.

## 3. Checklist

### The checklist must always be completed by the installation engineer

- If service is needed, you may be required to provide this document.
- Installation must always be carried out according to the installation and maintenance instructions
- Installation must always be carried out in a professional manner

### Following installation, the unit must be inspected and functional checks performed as indicated below:

#### Pipe installation

- Heat pump filled, positioned and adjusted in the correct manner according to the instructions.
- The heat pump is positioned so that it can be serviced
- Capacity of the charge/radiator pump (depending on type of system) for the flow required.
- Open radiator valves (depending on type of system) and other relevant valves.
- Tightness test
- Bleed the system
- Check proper operation of the requisite safety valves
- Requisite waste pipes connected to the floor drain (depending on type of system).

#### Electrical installation

- Power switch
- Correct tight wiring
- Requisite sensors fitted
- Accessories

#### Customer information (adapted to the relevant installation)

- Start-up with customer/installer
- Menus/controls for selected system
- Installation and maintenance manual supplied to the customer
- Check and filling, heating circuit
- Information on fine adjustments
- Alarm information
- Functional test of safety valves fitted
- Register your Installation Certificate at [ctc-heating.com](http://ctc-heating.com).
- Information on procedures for fault registration

---

Date/Customer

---

Date/Installer

## 4. Connection options

Below are the connection options (controlling products) available for CTC EcoPart 600M.

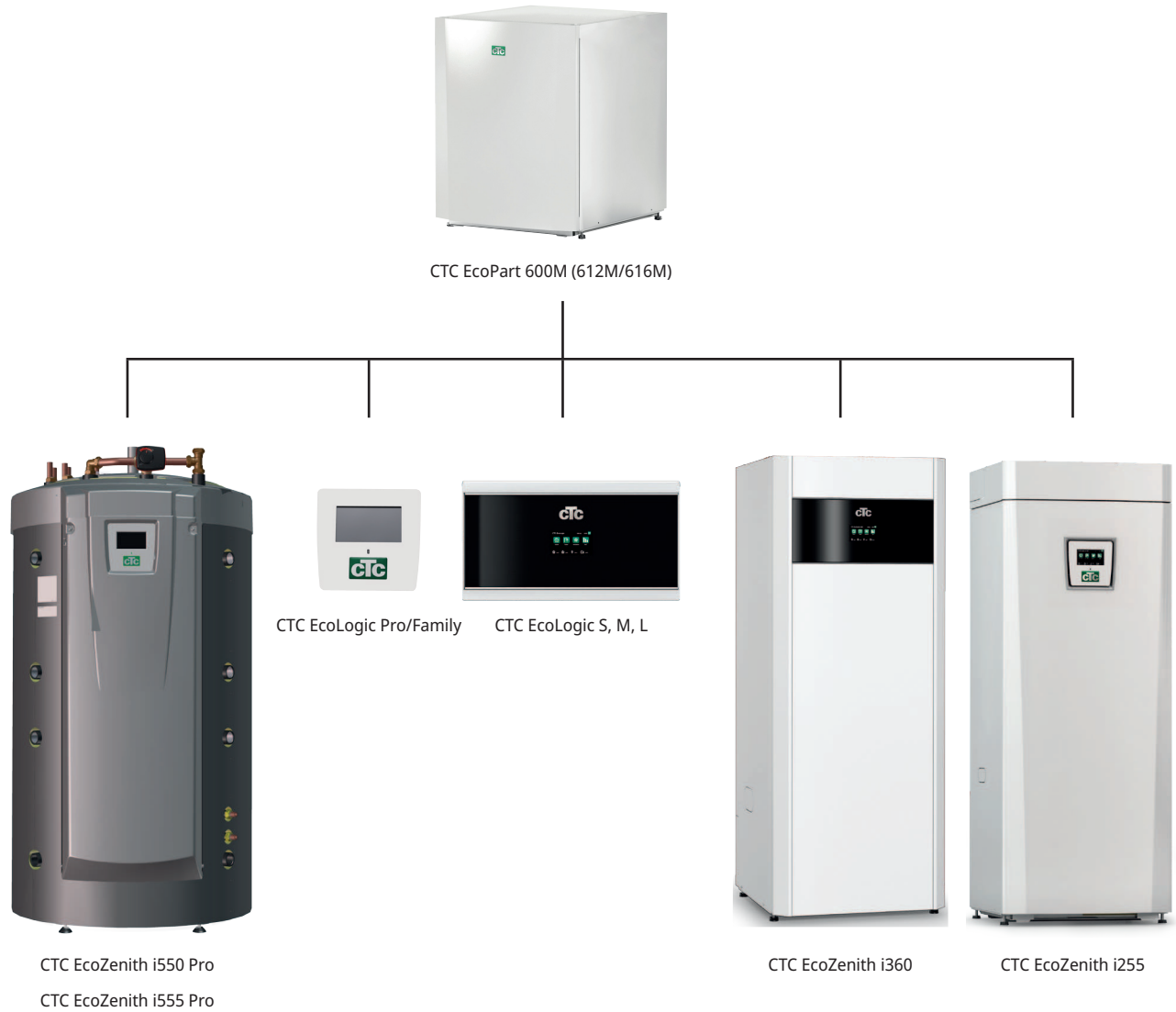

Control products must have software version (later):

!	CTC EcoZenith i550 Pro:	2019-06-20
!	CTC EcoZenith i555 Pro:	2020-07-01
!	CTC EcoLogic Pro/Family:	2019-08-01
!	CTC EcoLogic S, M, L:	2020-07-01
!	CTC EcoZenith i360:	2020-07-01
!	CTC EcoVent i360F:	2020-07-07
!	CTC EcoZenith i255:	2025-06-11

## 5. Technical data

### 5.1 CTC EcoPart 612M

Electrical data		CTC EcoPart 612M
CTC No.		588600001
Rated electrical data		400V 3N~ 50Hz
Rated power	kW	5.34
Rated current	A	9.7
Max starting current	A	2.3
Max group fuse	A	10
Ingress Protection class (IP)		IP X1

Operational data for heat pump			
Heating capacity max	W35 & B0   5   10	kW	12.14   13.11   13.49
Heating capacity nominal <sup>1)</sup>	W35 & B0   5   10	kW	6.08   7.1   8.1
Power input nominal <sup>1)</sup>	W35 & B0   5   10	kW	1.27   1.26   1.26
COP nominal <sup>1)</sup>	W35 & B0   5   10	-	4.78   5.62   6.45
SCOP <sup>2)</sup> 0/35 Pdesign cold climate			Pdesign = 11 kW, SCOP = 5.5
SCOP <sup>2)</sup> 0/55 Pdesign cold climate			Pdesign = 7 kW, SCOP = 4.3
SCOP <sup>2)</sup> 0/35 Pdesign average climate			Pdesign = 10 kW, SCOP = 5.4
SCOP <sup>2)</sup> 0/55 Pdesign average climate			Pdesign = 7 kW, SCOP = 4.1

<sup>1)</sup> EN14511

<sup>2)</sup> FprEN14825

Heating system		
Max. operating pressure (PS)	bar	6.0
Max. operating temperature (TS)	°C	100
Max. operating temperature, condenser	°C	65
Flow qw nominal: B0/W35, Δt=5K	l/s	0.26
Flow qw minimum: B0/W35, Δt=15K (at max RPS)	l/s	0.20
Max external available pressure head at nominal flow	kPa	53
Pump capacity		See diagram in the „Installation“ chapter.

Brine system		
Water volume (V)	l	4.1
Min./Max. operating pressure (PS)	bar	0.2 / 3.0
Min./Max. operating temperature (TS)	°C	-5 / +20
Flow qw nominal: B0/W35, Δt=3K	l/s	0.32
Flow qw minimum: B0/W35, Δt=6K (at max RPS)	l/s	0.27
Externally available pump pressure at nominal flow	kPa	113
Pump capacity		See diagram in the „Brine pump“ chapter.

Other data		
Refrigerant quantity (R407C, fluorinated greenhouse gas GWP 1774)	kg	2.4
CO <sub>2</sub> equivalent	ton	4.258
Interrupt value switch HP	MPa (bar)	3.1 (31)
Weight (packaged weight)	kg	170 (188)
Dimensions (depth x width x height)	mm	673 x 596 x 775
Sound power (L <sub>WA</sub> )	B0 W35/55 (EN12102) dB(A)	39 / 40.6
Sound pressure (L <sub>PA</sub> ) 1m	B0 W35 (EN11203) dB(A)	34
HP Keymark Cert. No.		012-073

The products are not covered by the periodical check for leaking refrigerant.

## 5.2 CTC EcoPart 616M

Electrical data		CTC EcoPart 616M
CTC No.		588600002
Rated electrical data		400V 3N~ 50Hz
Rated power	kW	7.0
Rated current	A	11.7
Max starting current	A	1.8
Max group fuse	A	13
Ingress Protection class (IP)		IP X1

Operational data for heat pump			
Heating capacity max	W35 & B0   5   10	kW	15.6   16.52   16.97
Heating capacity nominal <sup>1)</sup>	W35 & B0   5   10	kW	10.52   12.26   13.95
Power input nominal <sup>1)</sup>	W35 & B0   5   10	kW	2.34   2.42   2.56
COP nominal <sup>1)</sup>	W35 & B0   5   10	-	4.5   5.07   5.46
SCOP <sup>2)</sup> 0/35 Pdesign cold climate			Pdesign = 16 kW, SCOP = 5.5
SCOP <sup>2)</sup> 0/55 Pdesign cold climate			Pdesign = 16 kW, SCOP = 4.2
SCOP <sup>2)</sup> 0/35 Pdesign average climate			Pdesign = 16 kW, SCOP = 5.2
SCOP <sup>2)</sup> 0/55 Pdesign average climate			Pdesign = 16 kW, SCOP = 4.0

<sup>1)</sup> EN14511

<sup>2)</sup> FprEN14825

Heating system		
Max. operating pressure (PS)	bar	6.0
Max. operating temperature (TS)	°C	100
Max. operating temperature, condenser	°C	65
Flow qw nominal: B0/W35, Δt=5K	l/s	0.52
Flow qw minimum: B0/W35, Δt=15K (at max RPS)	l/s	0.27
Max external available pressure head at nominal flow	kPa	77
Pump capacity		See diagram in the „Installation“ chapter.

Brine system		
Water volume (V)	l	4.1
Min./Max. operating pressure (PS)	bar	0.2 / 3.0
Min./Max. operating temperature (TS)	°C	-5 / +20
Flow qw nominal: B0/W35, Δt=3K	l/s	0.58
Flow qw minimum: B0/W35, Δt=6K (at max RPS)	l/s	0.42
Externally available pump pressure at nominal flow	kPa	116
Pump capacity		See diagram in the „Brine pump“ chapter.

Other data			
Refrigerant quantity (R407C, fluorinated greenhouse gas GWP 1774)	kg	2.2	
CO <sub>2</sub> equivalent	ton	3.903	
Interrupt value switch HP	MPa (bar)	3.1 (31)	
Weight (packaged weight)	kg	172 (190)	
Dimensions (depth x width x height)	mm	673 x 596 x 775	
Sound power (L <sub>WA</sub> )	B0 W35/55 (EN12102)	dB(A)	42 / 42
Sound pressure (L <sub>PA</sub> ) 1m	B0 W35 (EN11203)	dB(A)	37
HP Keymark Cert. No.			012-SC0819-18

The products are not covered by the periodical check for leaking refrigerant.

### 5.3 Component location cooling module

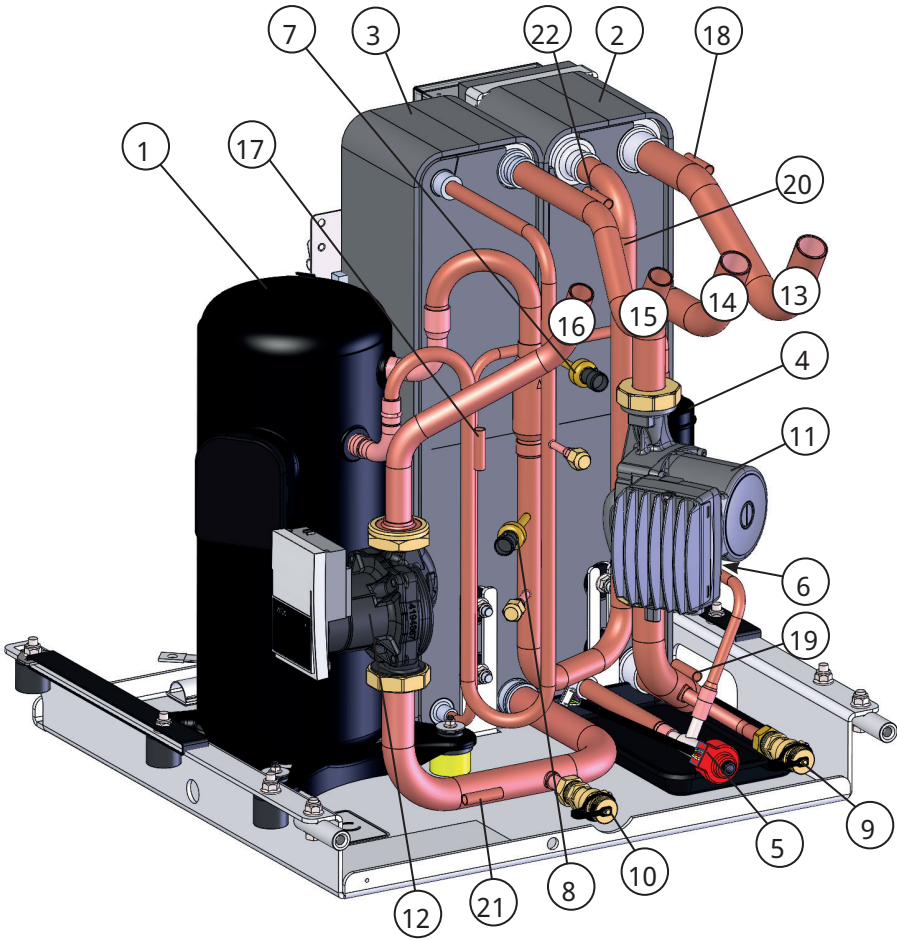

1. Compressor
2. Evaporator
3. Condenser
4. Drying filter
5. Expansion valve
6. High pressure switch
7. High pressure sensor
8. Low pressure sensor
9. Drain valve cold side/Brine
10. Drain valve warm side/Water
11. Brine pump
12. Charge pump
13. Brine in Ø28 mm (from rock)
14. Brine out Ø28 mm (to rock)
15. Heat carrier out (flow line) Ø22
16. Heat carrier in (return line) Ø22
17. Discharge sensor
18. Brine sensor in
19. Brine sensor out
20. Suction gas sensor
21. Sensor WP In
22. Sensor WP Out

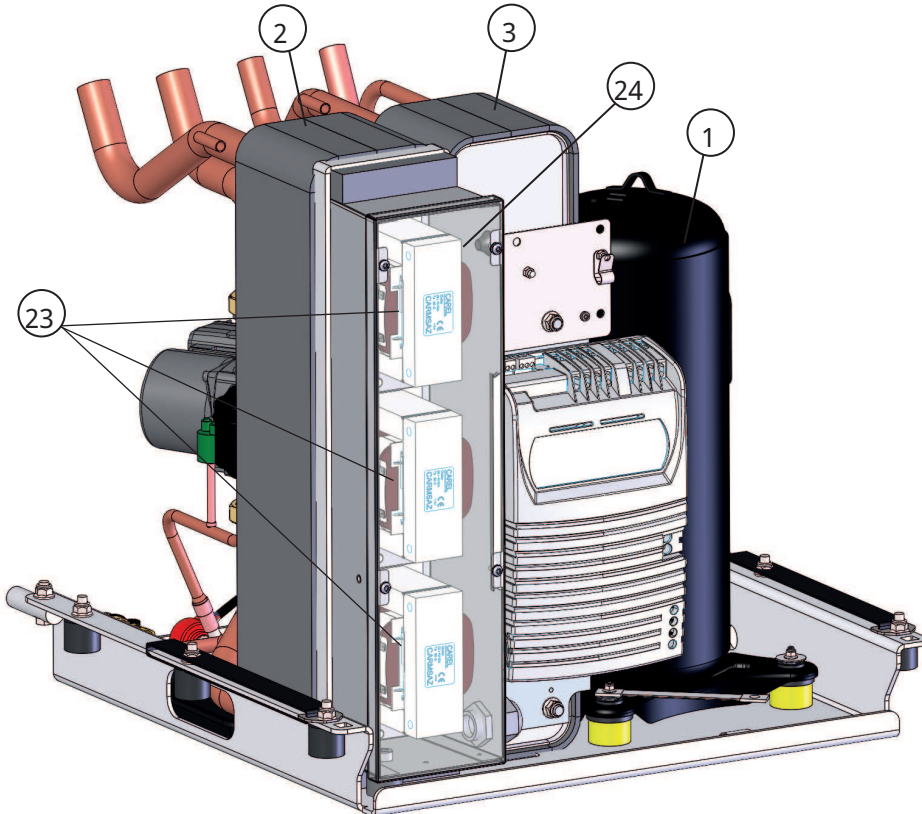

## 5.4 Dimensions diagram

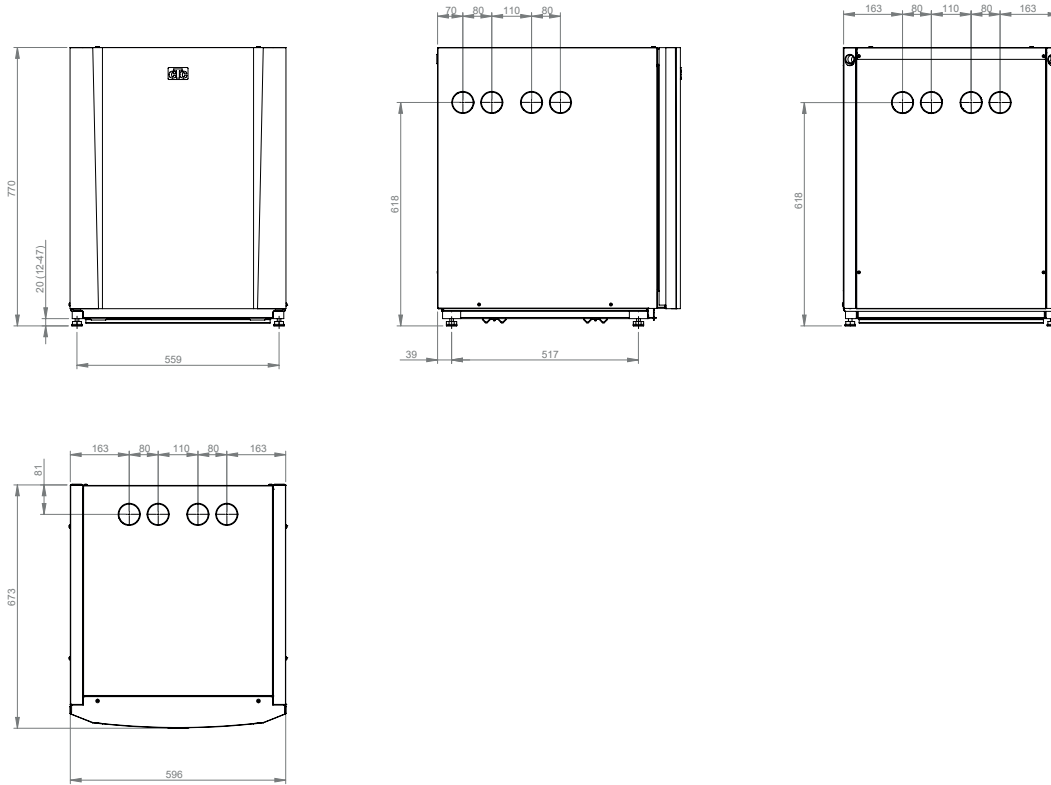

\*The product is delivered with the feet adjusted to a height of 770 mm.  
The feet enable height adjustment between 762-797 mm.

## 5.5 Refrigerant system

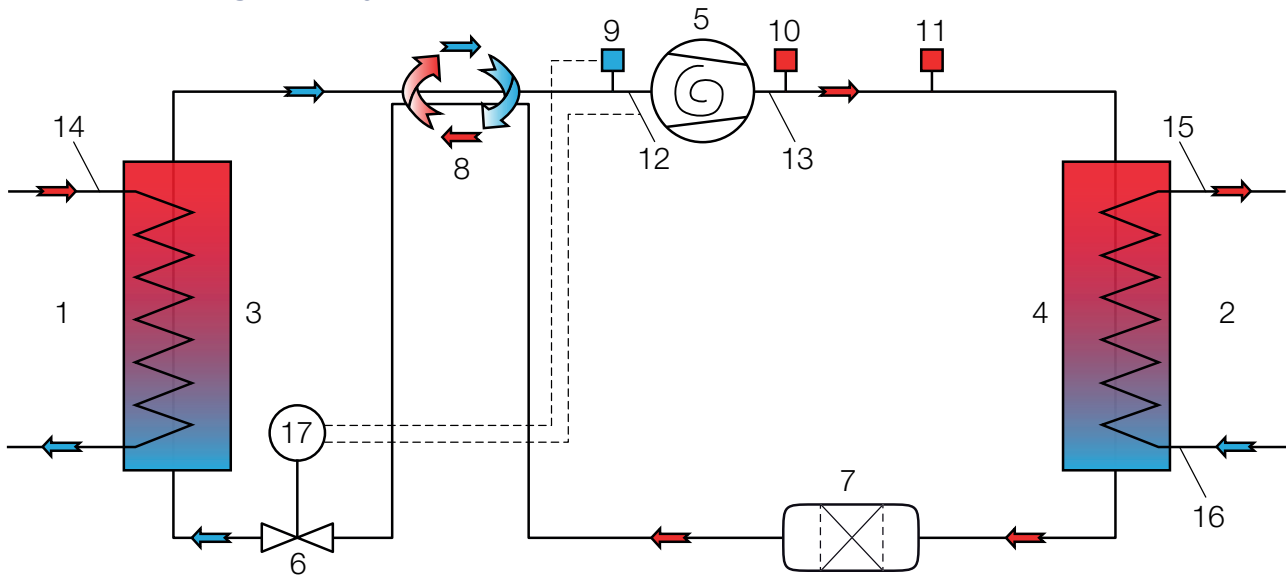

- |                                 |                               |                             |
|---------------------------------|-------------------------------|-----------------------------|
| 1. Brine (heat source)          | 7. Drying filter              | 13. Temp hot gas            |
| 2. Water                        | 8. Refrigerant heat exchanger | 14. Temp brine              |
| 3. Evaporator                   | 9. Low pressure sensor        | 15. Temp water out          |
| 4. Condenser                    | 10. High pressure sensor      | 16. Temp water in           |
| 5. Compressor                   | 11. High pressure switch      | 17. Control expansion valve |
| 6. Expansion valve (electronic) | 12. Temp suction gas          |                             |

## 5.6 Delivery includes

- Heat pump CTC EcoPart 600M
- Safety valve 1/2" 3 bar
- Filter ball valve magnet 3/4" \*
- Filter ball valve magnet 1" \*\*
- Filler manifold brine G25\*/G32\*\*
- Brine vessel\*
- 2 x rubber grommets Ø60 (for heat carrier tubes)
- 2 x edging 186 mm (for brine tubes)

\* Applies to CTC EcoPart 612M

\*\* Applies to CTC EcoPart 616M

## 6. Installation

The installation must be carried out in accordance with current standards and regulations. Refer to MIS 3005 and associated building regulations Part L, F & G. The heat pump must be connected to an expansion vessel in an open or closed system.

NB: If necessary, flush the radiator system before connecting!

Apply all the installation settings based on the description in the chapter on "First start".

### 6.1 Connection of the heat medium side

Flow and Return Lines are installed for the heat pump; at least Ø22 mm copper tubing for CTC EcoPart 612M and Ø28 mm for CTC EcoPart 616M. Route the pipes so that no other highest point is present where air can collect and obstruct circulation. If however this cannot be done, provide this highest point with an automatic bleeder.

#### 6.1.1 Circulation Pumps (charging pumps) (G11)

The following circulatory pumps are factory-fitted:

CTC EcoPart 616M: 25/125-130 PWM

CTC EcoPart 612M: 25/8-130 PWM

#### 6.1.2 Pump diagram CTC EcoPart 600M

##### CTC EcoPart 612M

25/8-130 PWM1

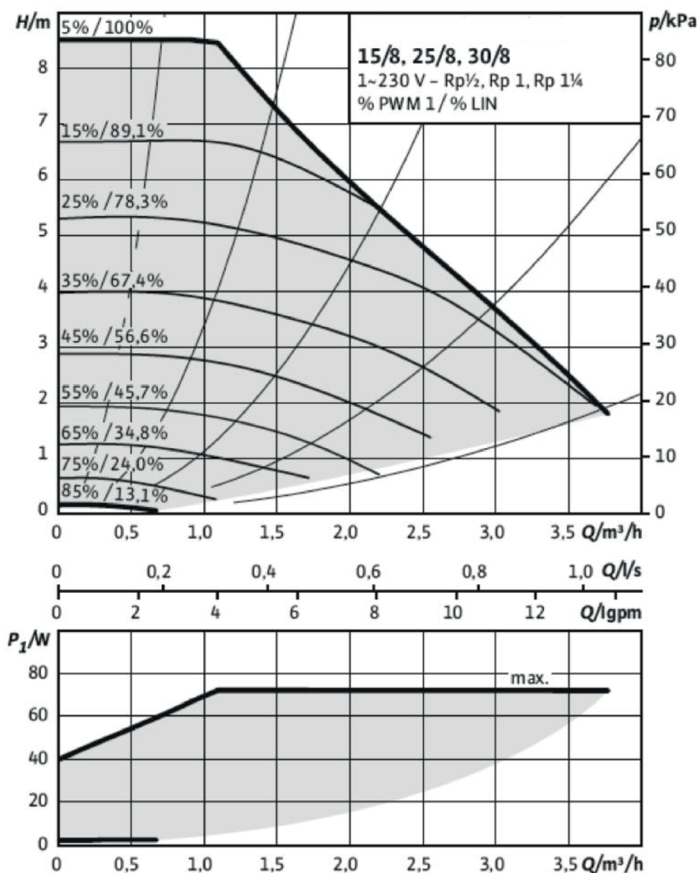

**CTC EcoPart 616M**

25/125-130 PWM, 1 x 230 V, 50/60 Hz

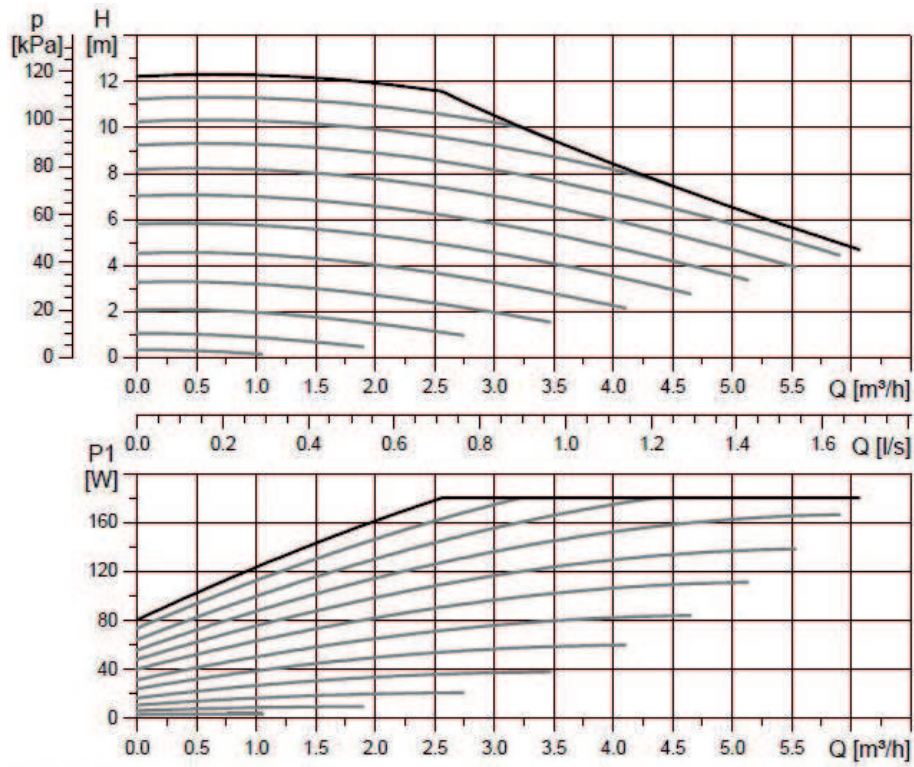

## 7. Connecting the cold carrier system (brine system)

The brine system, i.e. the ground collector loop, must be assembled and connected by a qualified tradesman in accordance with current regulations and design guidelines.

Care must be taken to ensure that no dirt gets on the collector hoses, which must be washed clean before being connected. The protective caps must remain in place at all times while work is in progress.

The temperature of the coolant system can fall below 0°C. It is therefore important that water-based lubricants, etc. are not used during installation. It is also important that all the components are insulated against condensation to prevent the build-up of ice.

### 7.1 Connections

The brine system may be connected to the right, left or top of the heat pump, as well as to its rear. Cut away the cover plate on the side where the brine system is to be connected. When the opening has been made through the cover plate, carry out the installation as follows:

1. In order to protect the brine hoses, fasten the protective edging provided around the edge of the opening in the insulation plate. Adjust the length of the protective edging to suit the opening as required.
2. Pass the brine hoses through the opening in the side cover plates and connect them. Ensure that the insulation covers all parts of the brine connection to prevent ice and condensation forming.
3. Then install the collector system according to the section "Brine system schematic diagram".

It is also possible to connect the primary flow on one side of the heat pump and the return on the other. Refer to section "Dimensions diagram" for measurements and dimensions. The pipe dimension between the heat pump and brine loop should be not less than  $\varnothing 28$  mm.

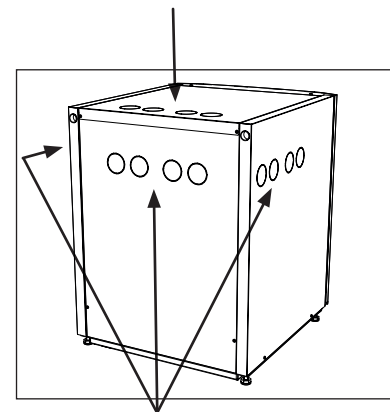

Possible take-offs, Brine hoses

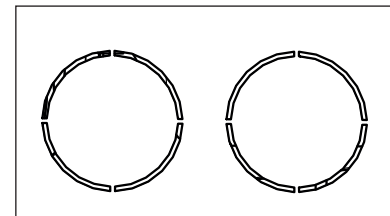

Edging strips (x2), supplied

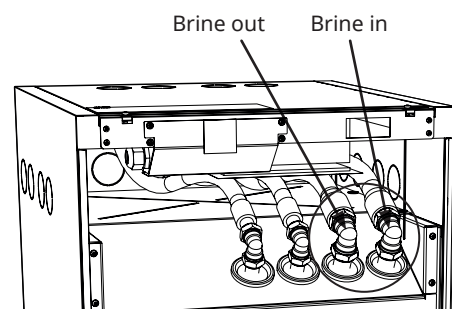

## 7.2 Brine system schematic diagram

The diagram shows the main connection for the brine system. The filling equipment is represented by the parts displayed with dashes. NB: Collector hoses must have a bleeding facility as air pockets can occur. Always check the filter (99) when filling and bleeding the brine system.

**!** The mixing vessel and filling pump must be of an adequate dimension.

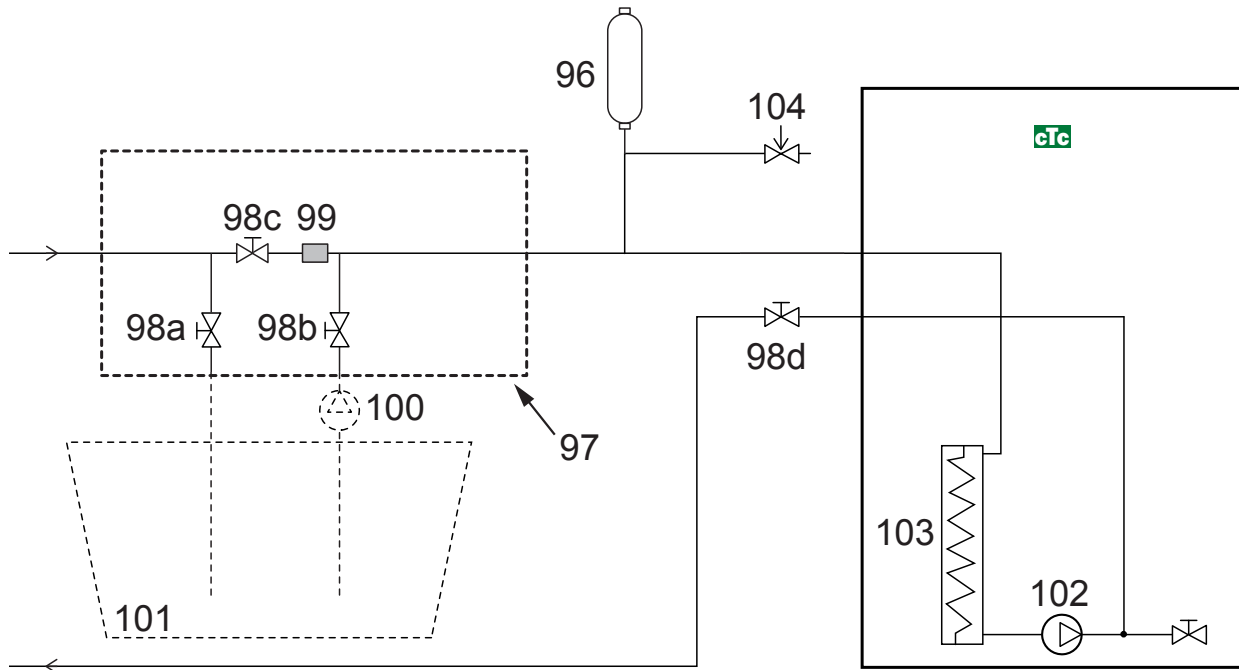

96	Level/expansion vessel	101	Mixing vessel
97	CTC filling kit	102	Brine pump
98	Shut-off valve	103	Evaporator
99	Filter	104	Safety valve 3 bar
100	External filling pump		

### 7.2.1 Valves

To facilitate servicing of the cooling unit, shut-off valves must be fitted to both the incoming and outgoing connections. Mount the valves (98d and 104) with the bifurcation so that you can later fill and bleed the collector circuit.

### 7.2.2 Insulation against condensation

All pipes in the brine system must be insulated against condensation to prevent the possibility of severe build-up of ice and condensation dripping.

### 7.2.3 Filling and venting

The collector circuit must not contain any air. Even the smallest amount of residual air can jeopardise the heat pump's operation.

Mix water and antifreeze solution in an open vessel. Connect hoses to the shut-off valves (98a and 98b) as shown in the figure. NB: The hoses must have a minimum diameter of 3/4". Connect a powerful external pump (100) for refilling and bleeding. Open the valves (98a and 98b) so that the brine passes through the mixing container (101). Also make sure that the valve (98d) is open.

To start the brine pump, refer to the manual of the controlling product.

Allow the brine to circulate in the system for a long period of time until it is completely free of air. There could still be air in the system, even though no air accompanies the liquid out.

Bleed the level vessel (96) by loosening the plug on the top of the level vessel.

Now close the valve (98a) while the filling pump continues to run. The filling pump (100) now pressurises the system. Also close the valve (98b) and shut off the filling pump.

If the level in the level vessel is too low, close the valves (98c) and (98d).

Unscrew the plug and fill the vessel to around 2/3 full. Screw the plug back in and open the valves (98c) and (98d).

### 7.2.4 Pressure/level switch

In some cases, extra protection is required due to local requirements or provisions. For example, the requirement in some areas is for the system to be installed within a water catchment area. If there is a leak, the compressor and brine pump stop and the Flow/level switch alarm appears on the controlling product's display. For connection, see the manual for the controlling product.

### 7.2.5 Post-installation check on brine system

After a few days, you must check the fluid level in the vessel. Fill if necessary and close the valve (98c) when filling.

### 7.2.6 Level vessel/Expansion vessel (CTC EcoPart 612M)

The level vessel (96) should be fitted to the incoming line from the borehole or ground, at the system's highest point. This applies to CTC EcoPart 612M (CTC EcoPart 616M has no level vessel). Bear in mind that the tank can produce condensate on its exterior. Mount the safety valve (104) according to the principle sketch and install the appropriate stopper at the top of the vessel. If the receptacle cannot be mounted at the highest point, a closed expansion vessel shall be fitted.

### 7.2.7 Filling kit with dirt filter

Arrows on the valve housing indicate the flow direction. Close the valve (98c) when cleaning the filter. Unscrew the filter cap and flush the filter clean. When refitting, the pin under the filter holder should be fed into the designated hole in the filter housing. Top up with a little brine, if necessary, before fitting the cap. The filter should be checked and cleaned after a short period of operation.

 Check the dirt filter after bleeding has been completed.

### 7.2.8 Brine

The brine circulates in a closed system. The fluid consists of water and antifreeze solution. Sentinel R500 & R500C are recommended for use in the brine circuit. The glycol is mixed at a concentration of slightly less than 30%, which is equivalent to fire risk class 2b and a freezing point of around -15°C.

It is a CTC recommendation that around 1 litre of brine/glycol is required per metre of collector hose, i.e. around 0.3 litres of antifreeze solution will be needed per metre of hose, for a hose diameter of 40 mm.

 The fluid must be thoroughly mixed before the heat pump is started.

### 7.2.9 Air pockets

To avoid air pockets, make sure that the collector hoses constantly rise towards the heat pump. If this is not possible, it must be possible to bleed the system at the high points. The filling pump usually copes with smaller local height discrepancies.

 Check the dirt filter in the brine system after a few days' operation.

### 7.2.10 Checking brine difference

When the heat pump is running, regularly check that the temperature difference between incoming and outgoing brine temperatures is not too large. If there is a large difference, one of the causes may be due to air in the system or a blocked filter. If this is the case, the heat pump triggers the alarm.

The alarm factory setting is 7°C, but 9°C is permitted for the first 72 hours while the compressor is running, as microbubbles in the system can reduce brine flow.

### 7.3 Coolant pump (G20)

For CTC EcoPart 612M and 616M, a circulation pump is used:

25/125-180 PWM, 1 x 230 V, 50/60 Hz.

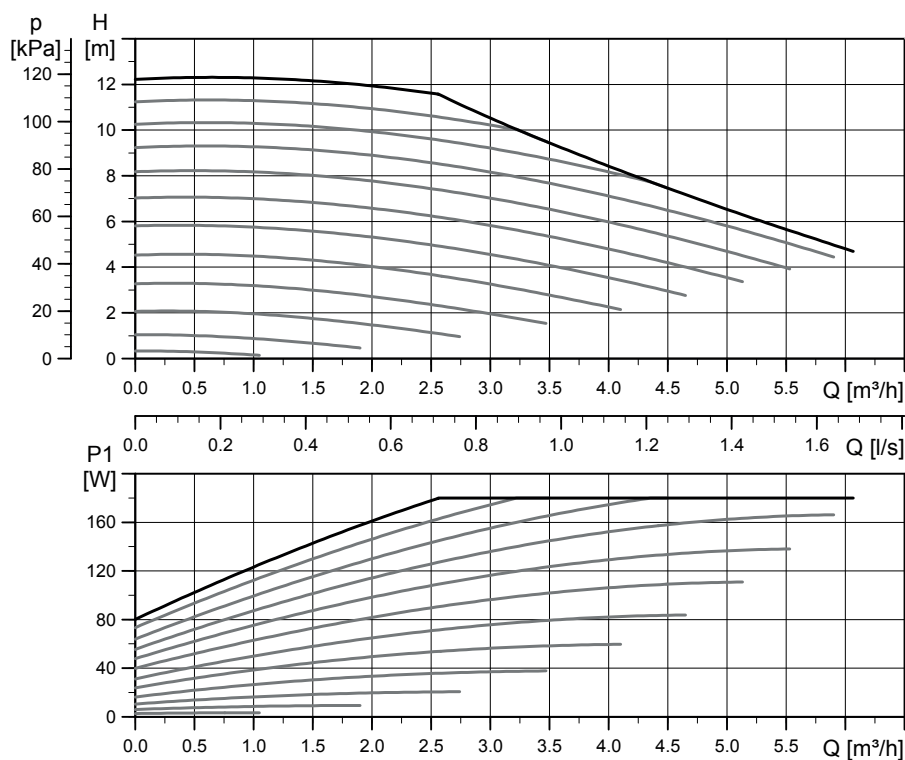

## 8. Electrical installation

Installation and heat pump connection must be performed by an authorised electrician. All wiring must be installed according to applicable provisions. Before the front panel is opened or other live components are made accessible, the power supply to the heat pump must be fully disconnected.



### 8.1 Electric installation 400V 3N~

CTC EcoPart 600M must be connected to 400V 3N~ 50Hz with protective earth.

The 2 meter long feed cable is fully wired in the heat pump and is routed via the terminal box X1 on the left rear.

#### 8.1.1 Omnipolar safety switch

The installation should be preceded by an all-pole safety switch according to overvoltage category III, which ensures disconnection from all electric power sources.

The CTC EcoPart 600M should be equipped with a faulty residual current switch with delayed deactivation.

#### 8.1.2 Alarm output

The CTC EcoPart 600M is fitted with a potential-free alarm output which is activated if any alarm is active in the heat pump. This output may be connected to a maximum load of 1A 250V AC. An external fuse should also be used. A cable approved for 230V AC must be used for connecting this output, irrespective of the load that is connected. For connection, see the chapter entitled "Wiring diagram".

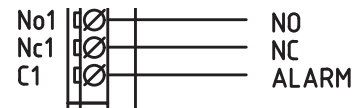
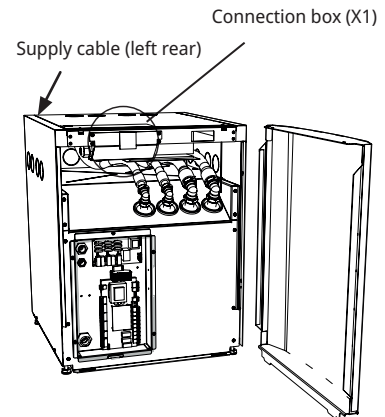

Alarm output, detailed view from electrical diagram

## 8.2 Communication connection

The 2 metre long communication cable is pre-wired in the heat pump and is routed via the connector box (X1) to the right rear of the heat pump for connection to the controlling product.

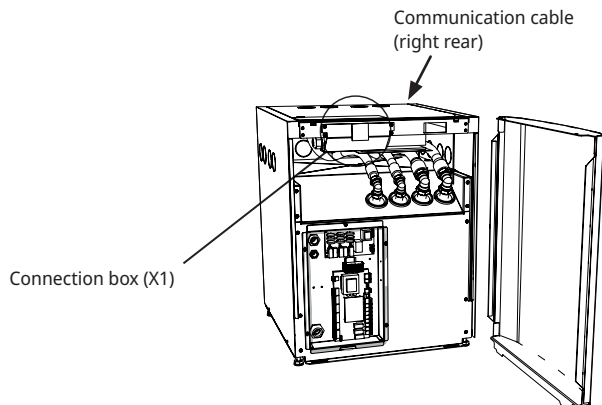

## 8.3 Option 1 - Connection of one heat pump

The communication cable of the heat pump (LiCY (TP)) is connected directly to the respective controlling product. When installing only one heat pump, make sure that DIP switch 2 is in the ON position (pre-set factory value).

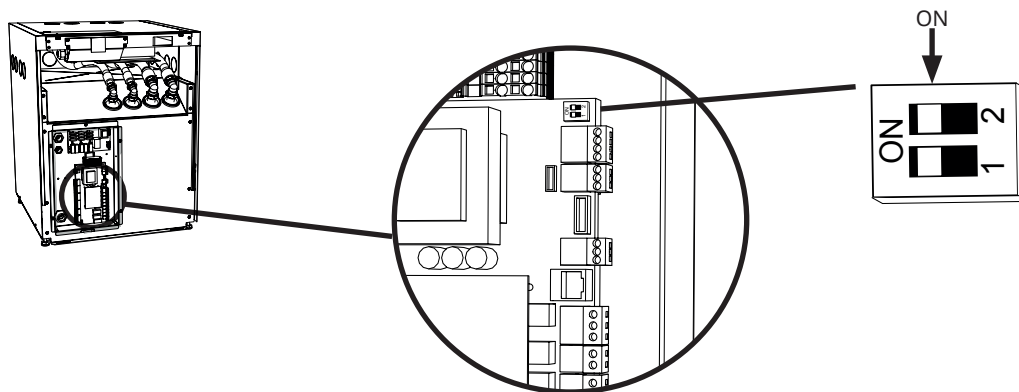

## 8.4 Option 2 – Series connection of heat pumps

When connecting more than one heat pump, the heat pumps (HP1, HP2, HP3 etc.) must be addressed. All CTC EcoPart 600M are factory-set addressed to HP1. The chapter “Connection control” shows how addressing is done from the display of the controlling product.

When connected in series, the shielding of the communication cable on the last heat pump must be connected to earth and the heat pump itself must be terminated. Make sure DIP switch 2 is in the ON position on the heat pump that is to be terminated.

The loop which connects position Sc of the control terminal block and PE on the mains terminal block must be removed on all heat pumps in the series connection except the last and replaced by the shielding, which is then connected up to the next heat pump (control terminal block position Sc).

**Controlling products:**

- -CTC EcoLogic L/Pro can control up to 10 heat pumps
- CTC EcoLogic M/Family can control up to 2 heat pumps.
- CTC EcoZenith i550/555 Pro can control up to 3 heat pumps.

**When connected in series, the last heat pump must be set to the terminated position.**

### Heat pumps in series connection

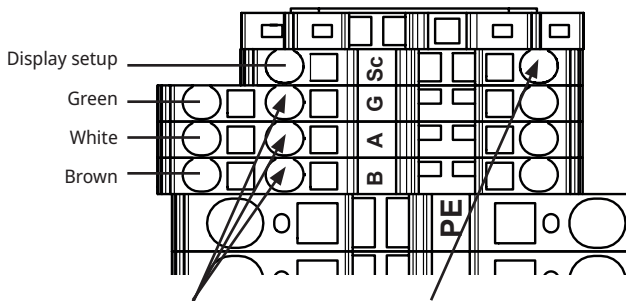
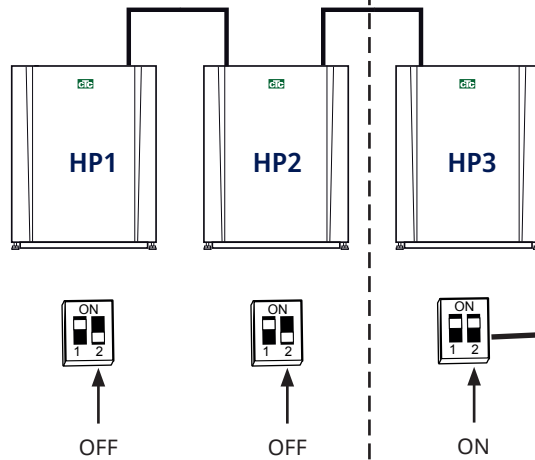

Connect each cable to the next heat pump in the series connection here.

Remove the jumper (PE-Sc), connect the screen to the next heat pump here (Sc).

### The last heat pump connected in series

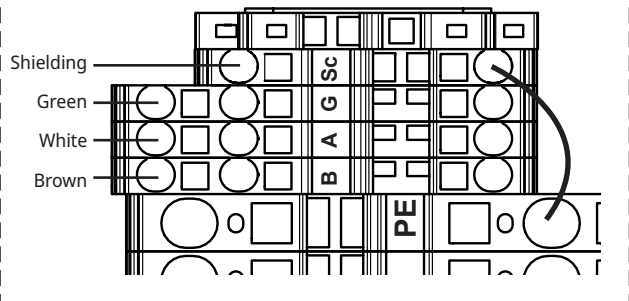
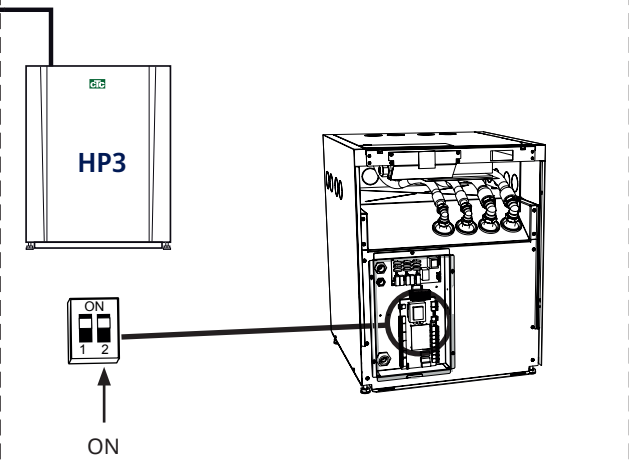

Make sure DIP switch 2 is in the ON position on the last heat pump in the series connection.

The jumper (PE-Sc) must be left in place.

## 8.5 Connecting the control system

### 8.5.1 Define number of heat pumps

Define the heat pumps in the controlling product's display under: "Installer/Define system/Heat pump".

Set the heat pumps contained in the system to position "On".

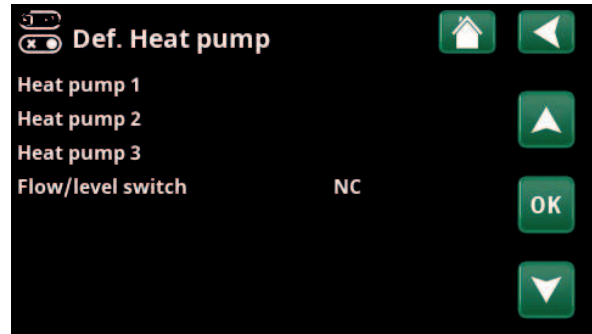

Example of a system with 3 heat pumps.

### 8.5.2 Numbering CTC EcoPart 600M as HP2

Applies to control launched in October 2020 with three connectors on the back of the display. 2 RJ-45 and 1 RJ-12.

NOTE! For displays with 2 connectors, see "Numbering CTC EcoPart 600M as A2".

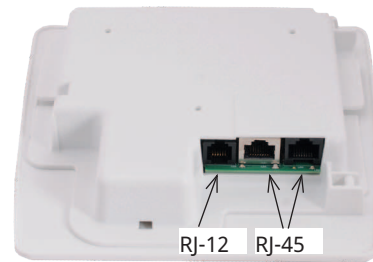

1. System disconnected from power.

2. Energise the control (CTC EcoLogic or CTC EcoZenith i555 Pro) as well as the CTC EcoPart 600M to be numbered as Heat Pump 2 (HP2).

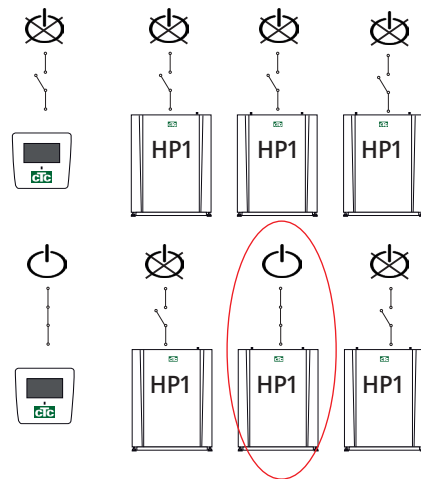

3. Wait for about 2 minutes.

4. Go to "Installer/Service/Set Address".

Select "Current address", press OK and press the down arrow until the current heat pump appears (HP1) Press OK.

Select "New address", press OK and use the arrow to scroll up and down until the address of the current heat pump address is shown (HP2). Press OK.

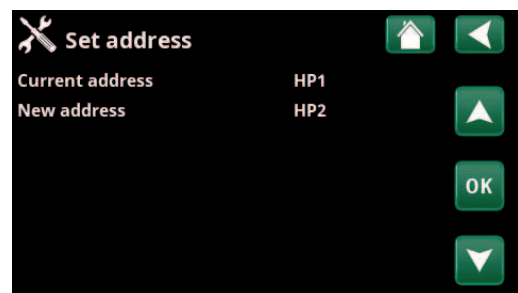

5. The heat pump is now numbered (HP2).

When you press OK, (HP1 and HP3)\* disappears and the row "Current address/New Address" will go dark.

*\*In this example, we have assumed that the heat pump is called HP1, which is the factory default. If the heat pump has already been renumbered, then select this number instead.*

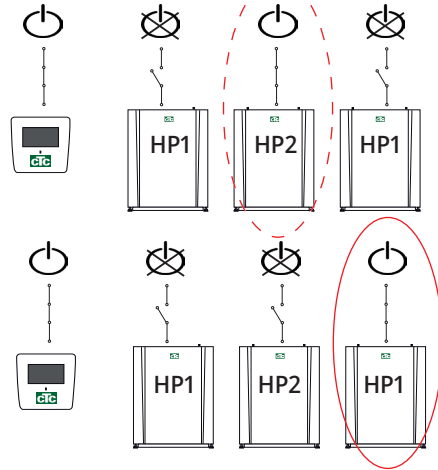
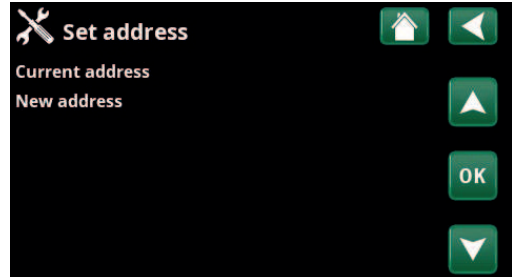

6. Number the other heat pumps:

Energise the next heat pump, which will be numbered heat pump 3 (HP3).

7. Wait 2 minutes.

8. Go to "Service/Set Address".

Select "Current address", press OK and press the down arrow until the current heat pump appears (HP1) Press OK.

Select "New address", press OK and press the up arrow until the current heat pump address appears (HP3). Press OK.

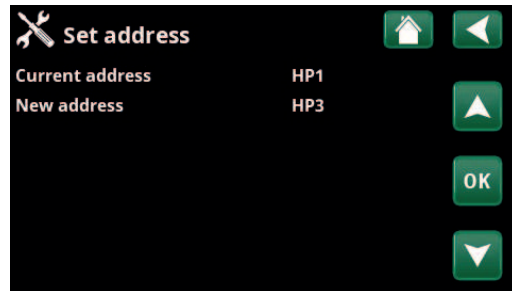

9. The heat pump is now numbered (HP3).

When you press OK, (HP1 and HP3)\* disappears and the row "Current address/New address" will go dark.

*\*In this example, we have assumed that the heat pump is called HP1, which is the factory default. If the heat pump has already been renumbered, then select this number instead.*

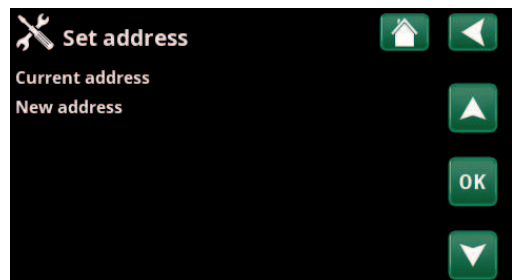

10. Redo the procedure according to the number of heat pumps to be numbered.

When all heat pumps are numbered and energised, they should be displayed when you press the heat pump symbol in the menu "Operation data". If any heat pump does not appear in the menu (communication with the heat pump fails) It may be because it has not been numbered as described above.

If you do not know the name of the heat pump, you can reset the numbering by using the "Select/Rename Heat Pump" menu (refer to points 9 and 10 above) to indicate all possible names of the heat pump, i.e. you select and confirm HP1 and then HP2 up to HP10 to ensure that the correct name is given.

Finally test in the menu "Installer/Service/Function test/Heat pump" that the respective heat pump starts.

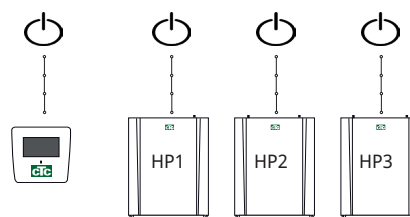

### 8.5.3 Worth knowing when addressing

#### Error set Address

The heat pump could not be found and numbered.

The heat pump was not what it was supposed to be called.

No communication with the heat pump.

Check that the heat pump is energised.

If the setting of the address fails, the latest heat pump addresses remain. In this example HP1 and HP2.

Make sure the heat pump is energised.

Try again with a new current address.

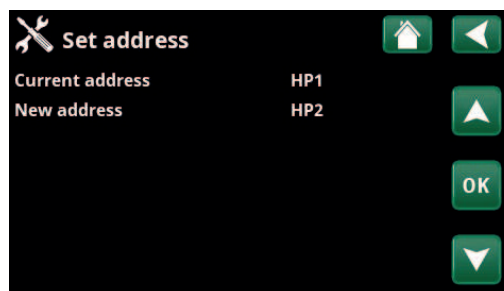
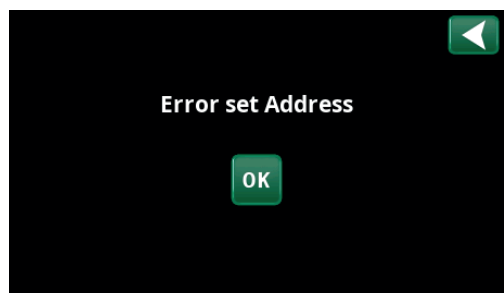

### 8.5.4 Numbering CTC EcoPart 600M as A2

Applies to older controls with 2 connectors on the back of the display.

1 RJ-45 and 1 RJ-12 for the CTC EcoZenith i550 Pro and CTC EcoLogic Pro/Family

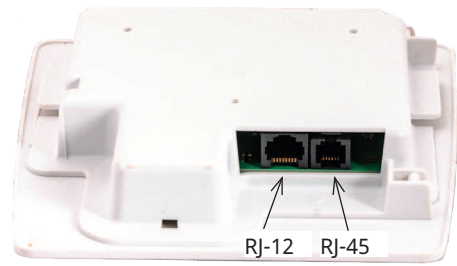

1. System disconnected from power.

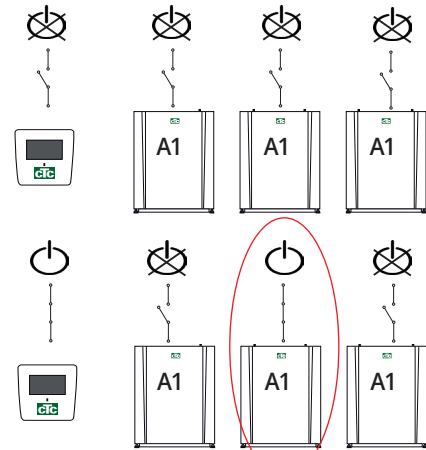

2. Energise the control (CTC EcoLogic Pro or CTC EcoZenith i550 Pro) as well as the CTC EcoPart 600M to be numbered as Heat Pump 2 (A2).

3. Wait approx 2 minutes until the heat pump is visible in the Operational Info menu.

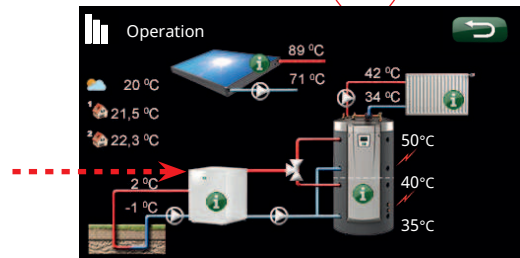

4. Go to Installer/Settings/Heat pump 2 and the row "Select/Rename Heat pump". Press OK.

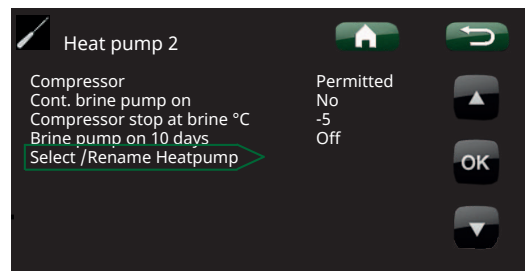

5. Press the arrow up until (A1)\* is displayed. Press OK.

After pressing OK, (A1)\* disappears and the "Select/Rename Heat Pump" row darkens.

*\*In this example, we have assumed that the heat pump is called A1, which is the factory default. If the heat pump has already been renumbered, then select this number instead.*

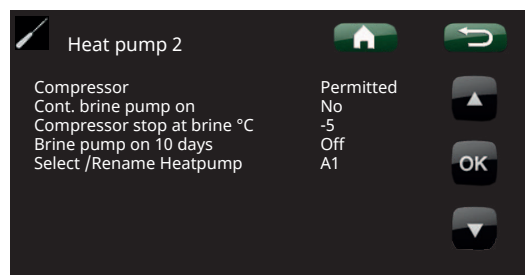

6. The heat pump is now numbered (A2).

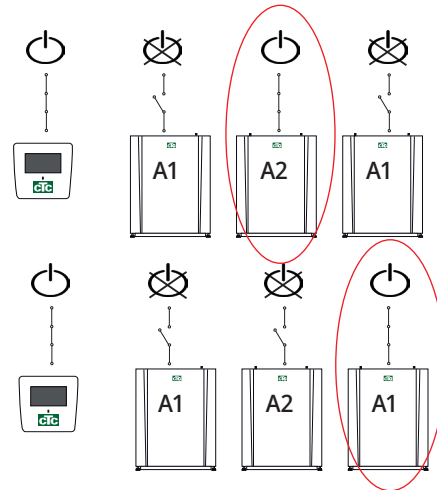

7. To number the other heat pumps:

Energise the control and the next heat pump to be numbered, which will be numbered pump 3 (A3).

8. Wait approx 2 minutes until the heat pump is visible in the operational information.

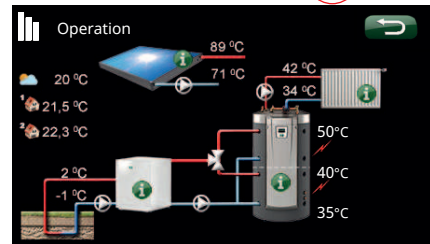

9. Go to Installer/Settings/Heat pump 3 and the row "Select/Rename Heat pump". Press OK.



10. Press the arrow up until (A1)\* is displayed. Press OK.

After pressing OK, (A1)\* disappears and the "Select/Rename Heat Pump" row darkens. The heat pump is now numbered (A3).

*\*In this example, we have assumed that the heat pump is called A1, which is the factory default. If the heat pump has already been renumbered, then select this number instead.*

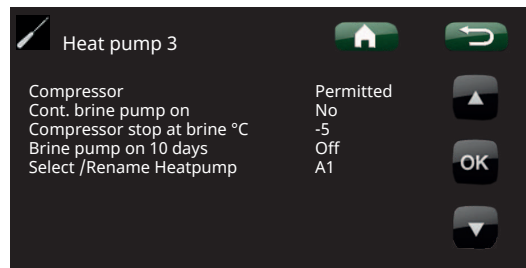

11. Redo the procedure according to the number of heat pumps to be numbered.

When all heat pumps are numbered and energised, they should be displayed when you press the heat pump symbol in the menu "Operation data". If any heat pump does not appear in the menu (communication with the heat pump fails) It may be because it has not been numbered as described above.

If you do not know the name of the heat pump, you can reset the numbering by using the "Select/Rename Heat Pump" menu (refer to points 9 and 10 above) to indicate all possible names of the heat pump, i.e. you select and confirm A1 and then A2 up to A10 to ensure that the correct name is given.

Finally test in the menu "Installer/Service/Function test/Heat pump" that the respective heat pump starts.

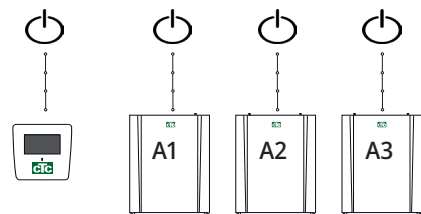

## 8.6 Wiring diagram

### 8.6.1 Cooling module

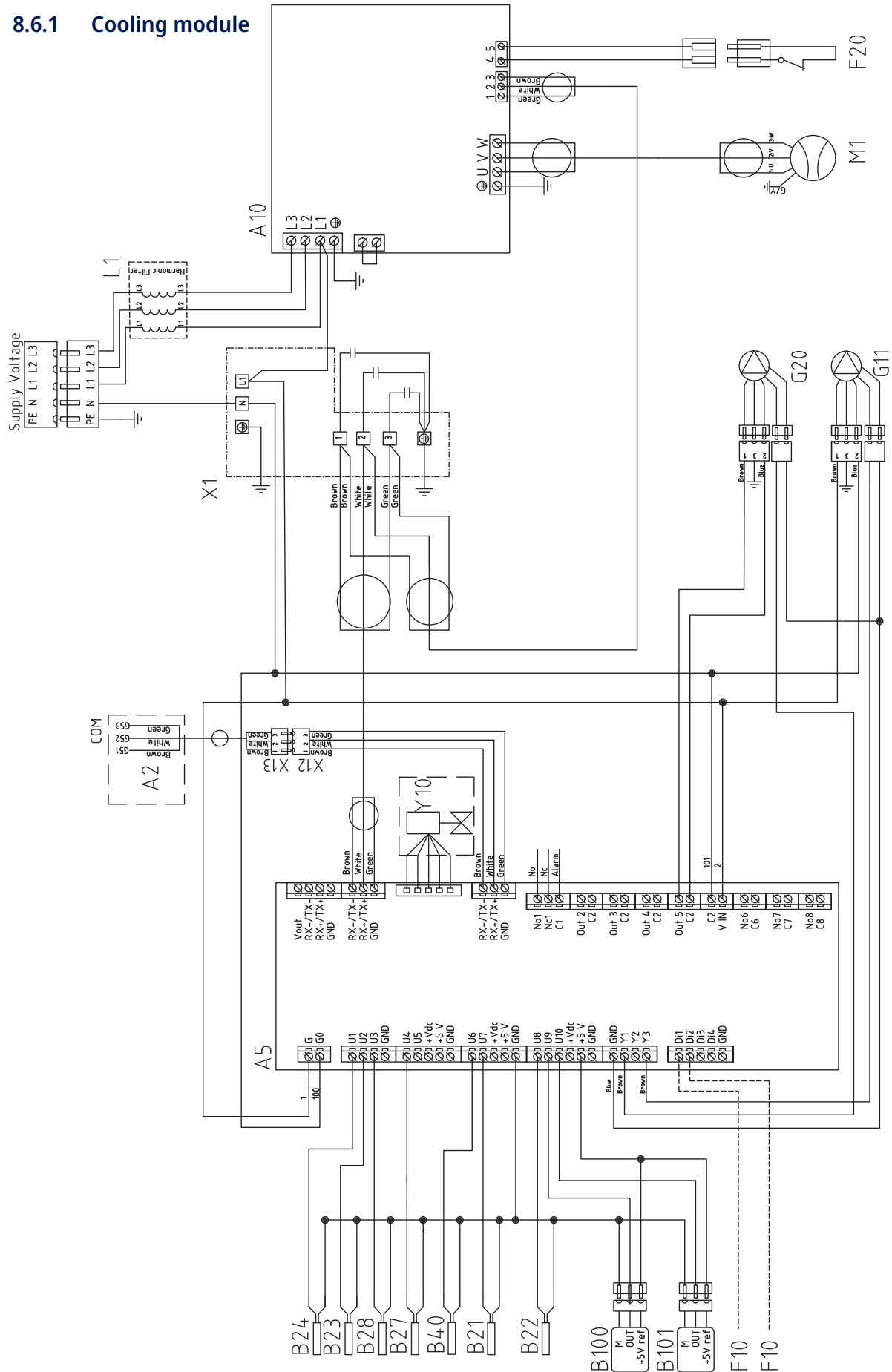

### 8.6.2 Connection box

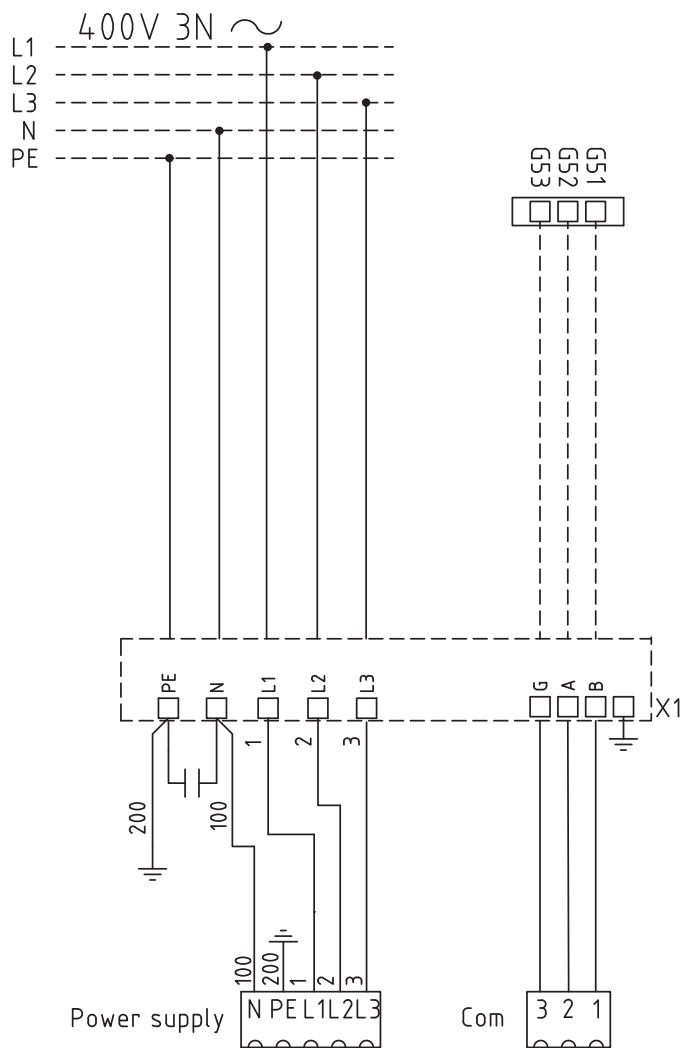

## 8.7 Parts list

A2	Relay/main card (CTC EcoLogic / CTC EcoZenith i555 Pro)
A5	HP control card
A10	Soft-start card with motor protection and contactor function
B21	Discharge sensor Type 3/ NTC
B22	Suction gas sensor Type 1/ NTC
B23	Brine sensor in Type 1/ NTC
B24	Brine sensor out Type 1/ NTC
B27	Heat pump in Type 2/ NTC
B28	Heat pump out Type 2/ NTC
B40	Sensor, AC choke temp NTC 015
B100	High pressure sensor
B101	Low pressure sensor
F10	Max thermostat
F20	High pressure switch
G11	Heat medium pump
G20	Brine pump
G21	Groundwater pump, signal 230 V, option
K1	Contactor
L1	AC choke (harmonic filter)
M1	Compressor
X1	Connection box, terminal
Y10	Expansion valve

## 8.8 Resistances for sensors

Temp °C	Sensor Type 1 NTC Resistance kΩ	Temp °C	Sensor Type 2 NTC Resistance kΩ	Temp °C	Sensor Type 3 NTC Resistance kΩ	Temp °C	NTC 015 Resistance kΩ
100	0.22	100	0.67	130	5.37	110	0.76
95	0.25	95	0.78	125	6.18	105	0.86
90	0.28	90	0.908	120	7.13	100	0.97
85	0.32	85	1.06	115	8.26	95	1.11
80	0.37	80	1.25	110	9.59	90	1.27
75	0.42	75	1.47	105	11.17	80	1.67
70	0.49	70	1.74	100	13.06	75	1.92
65	0.57	65	2.07	95	15.33	70	2.23
60	0.7	60	2.5	90	18.1	65	2.59
55	0.8	55	3.0	85	21.4	60	3.02
50	0.9	50	3.6	80	25.4	55	3.54
45	1.1	45	4.4	75	30.3	50	4.16
40	1.3	40	5.3	70	36.3	45	4.91
35	1.5	35	6.5	65	43.6	40	5.83
30	1.8	30	8.1	60	52.8	35	6.9
25	2.2	25	10	55	64.1	30	8.3
20	2.6	20	12.5	50	78.3	25	10.0
15	3.2	15	15.8	45	96.1	20	12.1
10	4	10	20	40	119	15	14.7
5	5	5	26	35	147	10	18
0	6	0	33	30	184	5	22
-5	7	-5	43	25	232	0	27
-10	9	-10	56	20	293	-5	34
-15	12	-15	74	15	373		
-20	15	-20	99	10	479		
-25	19	-25	134	5	619		
-30	25	-30	183				

## 9. First start

1. Check that the heating boiler and system are full of water and have been bled.
2. Check that all connections are tight.
3. Check that sensors and the radiator pump are connected to the power source.
4. Energise the heat pump by switching on the safety switch (the main switch).

Once the system has heated up, check that all connections are tight, the various systems have been bled, heat is coming out into the system and DHW is coming out at the tap locations.

## 10. Operation and Maintenance

When the installer has installed your new heat pump, you should check along with the installer that the system is in perfect operating condition. Let the installer show you where the power switches, controls and fuses are so that you know how the system works and how it should be maintained. Bleed the radiators (depending on type of system) after around three days of operation and top up with water if required.

### 10.1 Periodic maintenance

After three weeks' operation and then every three months during the first year. Then once a year:

- Check that the installation is free of leaks.
- Check that the product and system are free of air, bleed if needed – see the chapter "Connection of brine system".
- Check that the brine system is still pressurised and that the fluid level in the brine vessel is adequate/correct.
- The products do not require annual inspection for refrigerant leakage.

### 10.2 Operation stop

The heat pump is shut down using the operating switch. If there is a risk of the water freezing, drain off all the water from the CTC EcoPart 600M.

## 11. Troubleshooting

The CTC EcoPart 600M is designed to provide reliable operation and high levels of comfort, as well as a long service life.

If a fault occurs, you should always contact the installer who installed your unit. If the installer believes the malfunction is due to a materials or design fault, then they will contact CTC AB to check and rectify the issue. Always provide the heat pump's serial number.

### 11.1 Air problems

If you hear a rasping sound from the heat pump, check that it is properly bled. Top up with water where required, so that the correct pressure is achieved. If this noise recurs, call a technician to check the cause.

### 11.2 Alarm

Any alarms and information texts from the CTC EcoPart 600M are displayed in the controlling product; refer to that product's manual.





012



CTC AB Box 309 SE-341 26 Ljungby  
info@ctc.se +46 372 88 000  
www.ctc.se